

ANALYSIS OF INTERACTION BETWEEN THE ELEMENTS
IN CABLE-STAYED BRIDGEVerners Straupe¹, Ainars Paeglitis²✉*Institute of Transport Infrastructure Engineering, Riga Technical University,
Kalku street 1, LV-1658 Riga, Latvia**E-mails: ¹verners@celuprojekts.lv; ²ainars.paeglitis@rtu.lv*

Abstract. Large-span cable-stayed bridges design is impossible without a cable adjustment, which should be made in various stages of construction and for finished structure alike. There may be many concepts of regulation – the creation of design geometry (mainly used for relatively small- span pedestrian bridges), the optimization of shear or moment diagrams in carriageway's construction, the reduction of max tensile or compressive stresses in the load-bearing elements. Normally, the choice of mechanical and geometrical parameters for the main load bearing elements (cables, stiffness girder and pylons) which affect the flexibility of a bridge structure is an iterative process based on the structural engineering experience. The assumptions are to be tested by the Finite Element Method calculations and changed if necessary. This paper offers insight into the mathematical methods developed, based on the deformed shape of the cable-stayed bridge system. The method developed is demonstrated by example, where the system is optimized according to the type of cable-stayed bridge ("star" or "harp" design), geometrical parameters (lengths of stiffness beam sections, height of pylons) and the stiffness parameters (cross-section of cables, flexibility of the girder). This method allows analyzing the interactions between this data.

Keywords: cable-stayed bridge, load-bearing elements, post-tensioning, optimization, cable, stiffness girder, pylon.

1. Introduction

A rapid development of cable systems for bridges is occurring in the recent decades (Ruiz-Teran 2010). The number of cable-stayed bridges is increasing, their constructive solutions are diversifying and the design methods of cable-stayed bridges are improving (Malík 2004). Introduction of new materials renders possibility to more easily reach even longer spans (Kao *et al.* 2006; Serdjuks *et al.* 2008). At the same time, the cable-stayed bridges are becoming cheaper due to the reduction in material consumption and costs. The optimization of bridge structural design calls for improving methods of calculation, without having to sacrifice their safety (Janjic *et al.* 2003; Juozapaitis, Norkus 2007). Regulation of cables is a way of reducing stresses in the load-bearing components, hence simplifying the constructive solutions and cost reduction (Cruz, Almeida 1999).

Authors of this paper are working on the analytically obtained interaction between the cables and stiffening girder of cable-stayed bridge (Straupe, Paeglitis 2011). These formulas show how mechanical and geometric characteristics impact the deformations and stresses in the system. This will allow making an accurate initial assumption of

these components for further examination, using the Finite Element Method (FEM).

2. Description of the method

2.1. Deflection due to the uniformly distributed load

Strains in stiffening girder of a cable-stayed bridge depend on deformations of each cable from the assigned load. Non-linear problem of finding forces in cables and answering the question how they affect the stiffening girder can be calculated by researching deformed shape of the system. First, it is to be found how a simple beam with elastic supports deforms under the uniformly distributed dead load (Fig. 1).

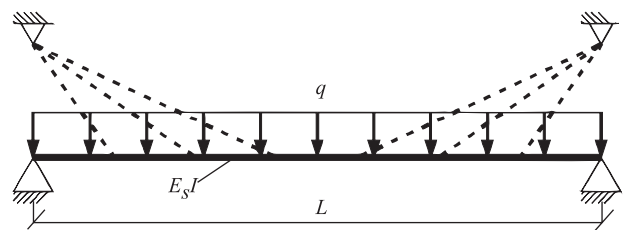

Fig. 1. Scheme for a cable-stayed bridge

Deflection of a simple beam can be found with a differential equation of deformed shape of axle: $E_s I y''(x) = M(x)$, where $y(x)$ – equation of the axle deformations; $M(x)$ – bending moment of the beam (Chen 1999).

Equation of the deformed shape of stiffening girder can be expressed:

$$y(x) = \frac{q}{24E_s I} (2Lx^3 - x^4 - L^3 x). \quad (1)$$

2.2. Deflection due to the symmetrically applied unit forces

Impact on the stiffening girder from symmetrical pair of cables can be modeled by applying the vertical unit forces in anchorage points of cables. Corresponding deflections can be found. The calculation scheme has three sections with different equations of bending moment (Fig. 2). Furthermore, these sections have different equations of the axle deflections. Using differential equations, three sections can be described as shown below.

$$\text{Section 1: } y_1(x) = \frac{1}{E_s I} \left(\frac{x^3}{6} + \frac{(z^2 - Lz)x}{2} \right). \quad (2)$$

$$\text{Section 2: } y_2(x) = \frac{z}{E_s I} \left(\frac{x^2}{2} - \frac{Lx}{2} + \frac{z^2}{6} \right). \quad (3)$$

$$\text{Section 3: } y_3(x) = \frac{1}{E_s I} \left(\frac{(x-L)^3}{6} + \frac{(z^2 - Lz)(x-L)}{2} \right). \quad (4)$$

2.3. Stresses in symmetrical cable pairs

The bending moment diagram of the stiffening girder depends on the vertical forces applied to the cable anchorage points. The magnitude of these forces depends on the extent to which the cable deforms (elongates) from the given load. The cable extension depends on their properties: length, cross-sectional area and the Young’s modulus of the material (Walther *et al.* 1999).

Taking into account the deformed shape of the system, the tensile force in a symmetrical pair of vertical cables (e.g. hangers of suspension bridge or an arc bridge) from the distributed load q can be expressed:

$$N_0 = \frac{q(2Lz^3 - z^4 - L^3 z)}{\frac{24E_s I L_v}{E_v F} - 16z^3 + 12Lz^2}, \quad (5)$$

where L_v – lengths of the cable, m; E_v – the Young’s modulus, kN/m²; F – the cross-sectional area, m²; f – elongation of the cable, m.

This expression will be further used in the calculations of the vertical component of tensile force for an inclined cable.

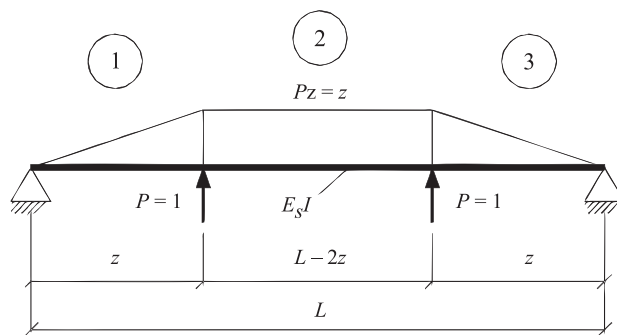

Fig. 2. The bending moment diagram of simple beam due to the symmetrical pair of vertical unit forces

2.4. Decrease in the max bending moment

One of the criteria for fixing the cable prestressing force is aimed at the reduction of max positive and negative bending moments (the presented method with some modifications is valid also for other purposes: controlling the permissible tensile and compressive stresses, etc.) (Kachurin, Bragin 1971). In a theoretical case with an extra stiff cable ($E_v F \rightarrow \infty$), the stiffening girder could be observed as a multi-span beam. However, if the elastic supports being able to move vertically, the system tends to the values of a simple beam (if the $E_v F \rightarrow 0$). Depending on the possible vertical movements of supports, the negative moment will reduce, while the positive moment tends to increase (Fig. 3).

The Eq (5) shows dependence of the tensile strength of vertical cable on $E_v F$ of the cable. The law of independence of force effects can be applied for finding the vertical force in the anchorage points of cables, at which the moment values level off. Hence this result obtained will serve as an equivalent value $E_v F_e$ for finding the extension of the cables which gives the required values of the bending moment. The cable force will be used to determine

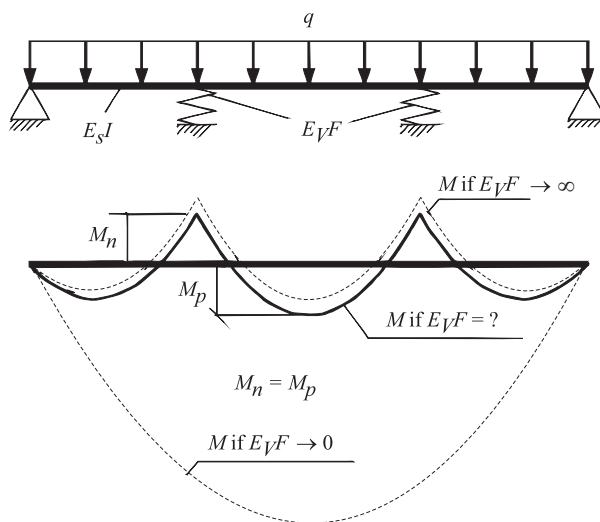

Fig. 3. Bending moment dependence on the stiffness of supports

the shortening (prestressing) value of the cable with real stiffness $E_v F$.

In the layout with a symmetrical pair of vertical forces (Fig. 2), the middle section includes support with area of max negative moment and center of the span with max positive moment. From the condition $M_p = M_n$, defined in Fig. 3, the vertical component of cable force can be expressed:

$$N_0 = \frac{-M_q(z) - M_q\left(\frac{L}{2}\right)}{M_1(z) + M_1\left(\frac{L}{2}\right)}. \quad (6)$$

Value of $E_v F_e$ can be found by putting Eq (5) into (6):

$$E_v F_e = \frac{6E_s IL}{\frac{2Lz^4 - z^5 - L^3 z^2}{z^2 - Lz - \frac{L^2}{4}} + 4z^3 - 3Lz^2}. \quad (7)$$

The corresponding vertical displacement of the cables anchorage point is:

$$f = \frac{N_0 L_v}{E_v F_e} = N_0 L_v \frac{2Lz^4 - z^5 - L^3 z^2}{6E_s IL \left(z^2 - Lz - \frac{L^2}{4}\right)}. \quad (8)$$

If the cable with real $E_v F$ is chosen, this correlation changes into Eq (9):

$$f + \Delta = \frac{N_0 L_v}{E_v F}, \quad (9)$$

where Δ – the shortening (prestressing) value of the cable with stiffness $E_v F$ used to reduce the bending moments.

According to the principles of this calculation, the tensile force of cables under uniformly distributed load is related to the deflection of the stiffening girder in cables anchorage point. This deflection is determined by the assumption of equilibrium of moments M_p and M_n . The

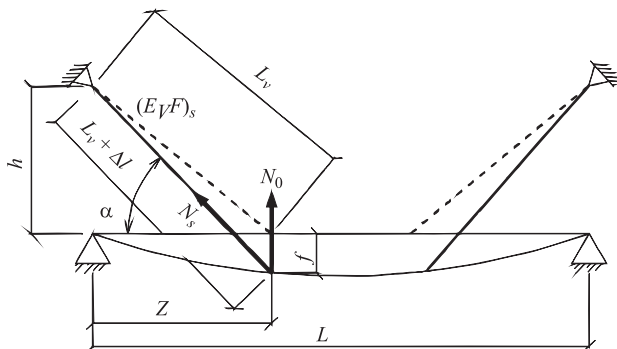

Fig. 4. Deformed shape of system with a symmetrical pair of the inclined cables

Eqs (5) and (8) show that the tensile force of cables and deflection of the stiffening girder are not determined using parameters of the cable. Therefore $E_v F$ of the cable can be chosen using the Eq (6) which provides the required tensioning force.

2.5. Influence of the cables inclination

Deformation of the stiffening girder not only elongates the inclined cable, but also turns it (Fig. 4). This turn affects the movement of the anchorage point of cable. This assignment can be solved using the above equations for the vertical cable found.

The slope of cable can be taken into account by finding an appropriate $E_v F_s$ of the cable. This is a value which gives the same deflections of the stiffening girder as the previously found ones. The elongation Δl and the tensile force N_s of inclined cable can be found:

$$\Delta l = \frac{N_s L_v}{E_v F_s}, \quad (10)$$

$$N_s = \frac{\Delta l E_v F_s}{L_v}, \quad (11)$$

where h – the height of the pylon, m.

From geometrical shape of system the following equations can be expressed:

$$\Delta l = \sqrt{(h+f)^2 + z^2} - L_v, \quad (12)$$

$$\sin \alpha = \frac{h+f}{L_v + \Delta l} = \frac{N_0}{N_s} = \frac{f E_v F L_v}{h \Delta l E_v F_s}, \quad (13)$$

$$E_v F_s = \frac{f E_v F L_v (L_v + \Delta l)}{h \Delta l (h+f)} = \frac{f E_v F L_v \sqrt{(h+f)^2 + z^2}}{h \left(\sqrt{(h+f)^2 + z^2} - L_v \right) (h+f)}. \quad (14)$$

Here the length of cable is: $L_v = \sqrt{h^2 + z^2}$.

The tensile force in inclined cable can be found as follows:

$$N_s = \frac{\Delta l E_v F_s}{L_v} = \frac{f E_v F \sqrt{(h+f)^2 + z^2}}{h(h+f)}. \quad (15)$$

2.6. Solution for multiple symmetrical cable pairs

Previously, the tensile force was found in one symmetrical cable pair caused by the uniformly distributed load. Likewise, this force can be found from the deformations of the stiffening girder:

$$N = \frac{y(z)}{\frac{L_v}{E_v F} - y_2(z)}. \quad (16)$$

The forces in n pairs of the symmetrical cables can be found by solving a system of Eq (17).

$$\begin{cases} y(z_1) + N_1 \left(y_{11}(z_1) - \frac{L_{v1}}{E_v F_1} \right) + N_2 y_{12}(z_1) + N_3 y_{13}(z_1) + \dots + N_n y_{1n}(z_1) = 0, \\ y(z_2) + N_1 y_{21}(z_2) + N_2 \left(y_{12}(z_2) - \frac{L_{v2}}{E_v F_2} \right) + N_3 y_{13}(z_2) + \dots + N_n y_{1n}(z_2) = 0, \\ \dots \\ y(z_n) + N_1 y_{21}(z_n) + N_2 y_{22}(z_n) + N_3 y_{23}(z_n) + \dots + N_n \left(y_{1n}(z_n) - \frac{L_{vn}}{E_v F_n} \right) = 0. \end{cases} \quad (17)$$

In this system of equations for quantifiable which describes area before point of cable anchor function $y_2(x)$ is to be used, but for further quantifiable function $y_1(x)$. For calculation point both functions can be used.

2.7. Optimal span of the outer section

The span of outer section will be chosen in a way that the max positive and negative bending moments within this section take the same absolute value.

Using the parabolic equation for the layout shown in Fig. 5, the optimal span of the outer section can be determined as follows: $b = 0.85355L_0$. The max bending moment will be reached at the distance: $m = 0.85355L_0 - 0.5L_0 = 0.35355L_0$.

3. The application example

3.1. Definition of the cable system

Previously found analytical expressions can be used for selecting parameters in the cable-stayed bridge and to study their interaction. Final calculations should be carried by the FEM program that verifies compliance of the obtained data with the chosen criteria (Bruer *et al.* 1999; Gribniak *et al.* 2010). Randomly some points of diagrams given

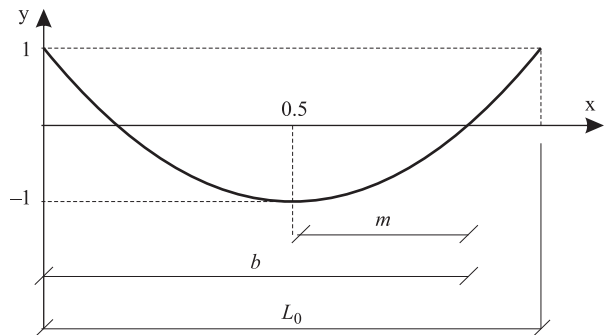

Fig. 5. The bending moment diagram in the outer section

below have been verified by the FEM program and a very good correlation has been found thereto.

This example should serve to estimate the equations and methodology established, as well as to verify its accuracy. Therefore, some factors were not considered (e.g., deformations of pylons from the moving loads and the cable sag effect) which are the issues for further examination of this method.

The analyzed system of a cable-stayed bridge is presented in Fig. 6. Initially, the pylons are adopted by the

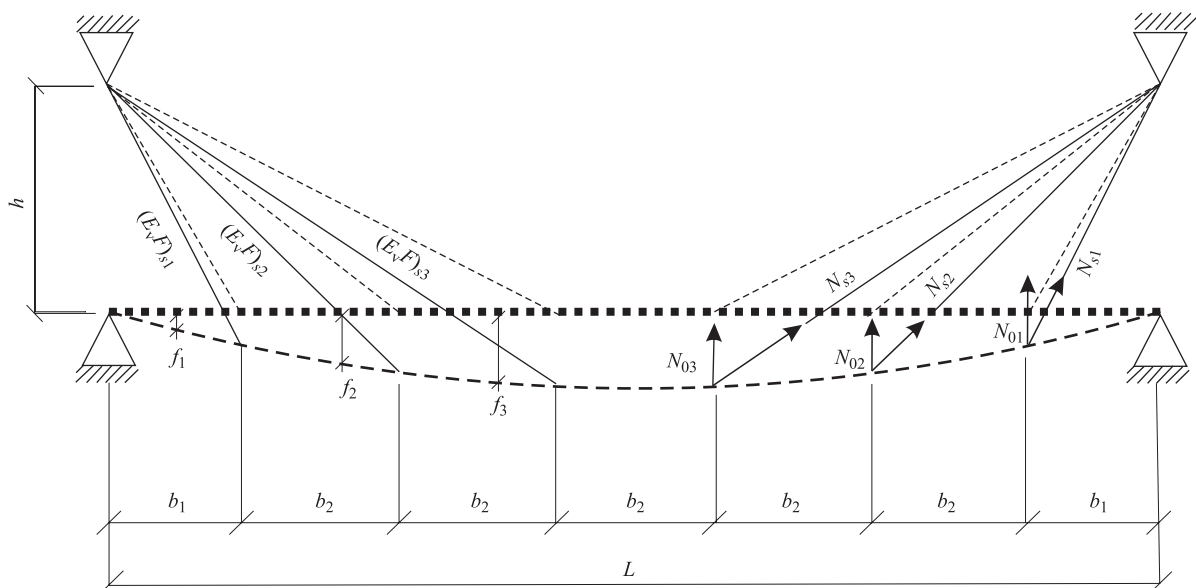

Fig. 6. Deformed shape of a cable-stayed bridge

height $h = 50$ m. Span with the length $L = 231$ m is divided into 7 sections.

The assumption of the cross-sectional geometry and loads of the bridges are not described, as they are not a subject matter of this paper. Initially, the following parameters of the stiffening girder are adopted:

- second moment of area of the stiffening girder: $I = 41.7476 \text{ m}^4$;
- the Young's modulus of the stiffening girder: $E_s = 36 \text{ GPa}$;
- the uniformly distributed load $q = 1300 \text{ kN/m}$.

The stiffening girder is divided into sections according to the assumptions listed above:

$$b_2 = \frac{L}{2 \times 0.85355 + 5} = \frac{231}{6.7071} = 34.441 \text{ m},$$

$$b_1 = 0.85355 b_2 = 0.85355 \times 34.441 = 29.397 \text{ m}.$$

3.2. Definition of the desired bending moment diagram

Symmetrical vertical forces added to the anchorage points of cables will provide a bending moment diagram which is similar to the one shown in Fig. 2, while three pairs of forces are used now.

The values of bending moment diagram caused by the uniformly distributed load on simple beam can be calculated at the beginning and at the end of middle section (section with span b_2). Following the tensioning of cables at the beginning of the section there will be the max negative value, but in the middle of the section – the max positive value. These values are equal, but with opposite signs. Knowing these values at the early stages of the calculation, allows finding the suitable parameters of the stiffening girder.

$$M_p = M_n = \frac{M_{load} \left(\frac{L}{2} \right) - M_{load} \left(\frac{L}{2} - \frac{b_2}{2} \right)}{2} = 96.38 \text{ MNm}.$$

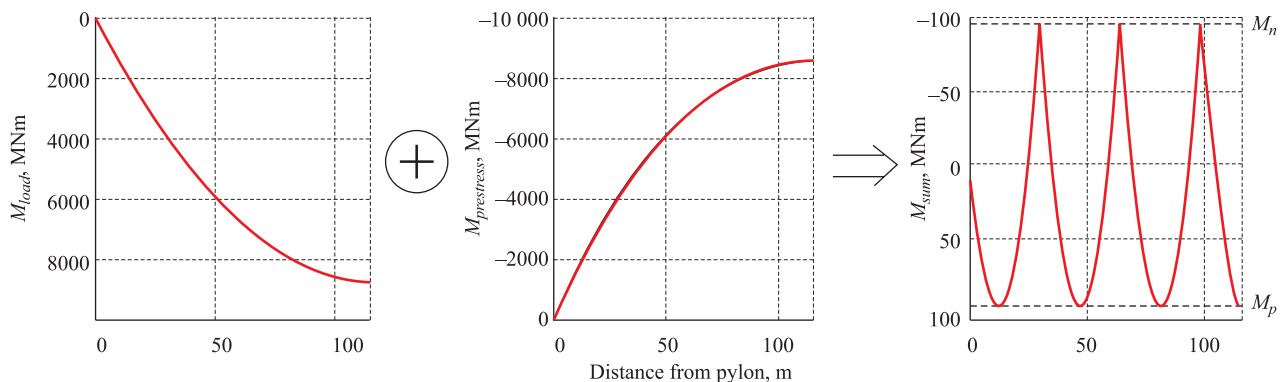

Fig. 7. Obtaining the desired bending moment diagram

Bending moments values for this example are given in Table 1. Fig. 7 shows the same on diagrams. Due to the symmetry, only the half of the bridge is presented.

Table 1. Bending moments in the characteristic points

x , m	M_{load} , MNm	$M_{prestres}$, MNm	M_{sum} , MNm
0.0	0.00	0.00	0.00
12.2	1731.97	-1635.59	96.38
29.4	3852.27	-3948.65	-96.38
46.6	5587.08	-5490.70	96.38
63.8	6936.36	-7032.74	-96.38
81.1	7900.14	-7803.76	96.38
98.3	8478.40	-8574.78	-96.38
115.5	8671.16	-8574.78	96.38

Solving the equations system similar to (17) allows to obtain the vertical component of tensile force of cables N_0 , displacements of the stiffening girder f , the corresponding tensile strength in star-type cable system N_s (adopted to the pylon height 50 m) and the necessary stiffness of the inclined cable $E_v F_s$. The results are included in the Table 2.

Table 2. Obtained parameters of cables

Cable No.	N_0 , MN	f , mm	N_s , MN	$E_v F_s$, MN
1	44.77	56.67	51.92	61 638
2	44.77	102.62	72.52	92 877
3	44.77	125.59	98.54	19 0618

3.3. Some tasks for optimization

Tasks for optimization listed below are given in Figs 8 to 15. All of them are found using the analytical approach described in this paper.

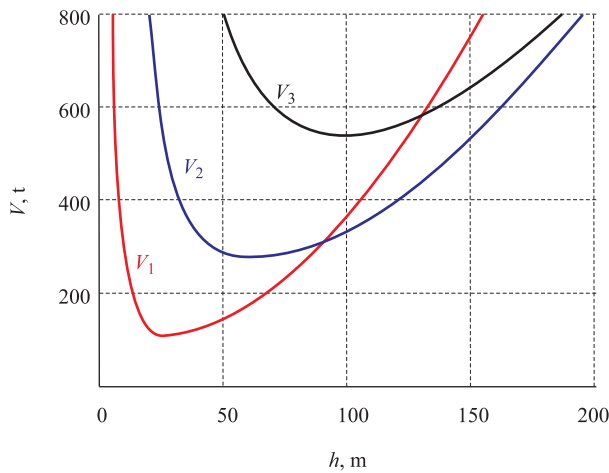

Fig. 8. Consumption of the inclined cables V (tons) depending on the slope of cables (a star-type cable-stayed bridge is observed and height of the pylons h (m) is used as a variable)

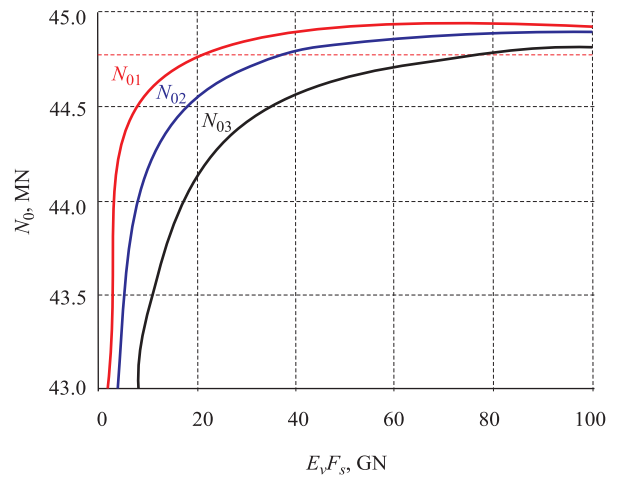

Fig. 11. Vertical component N_0 (MN) of the tensioning force of cables depending on stiffness $E_v F_s$ (GN) of cables (constant value of $E_s I$ of the stiffening girders is used)

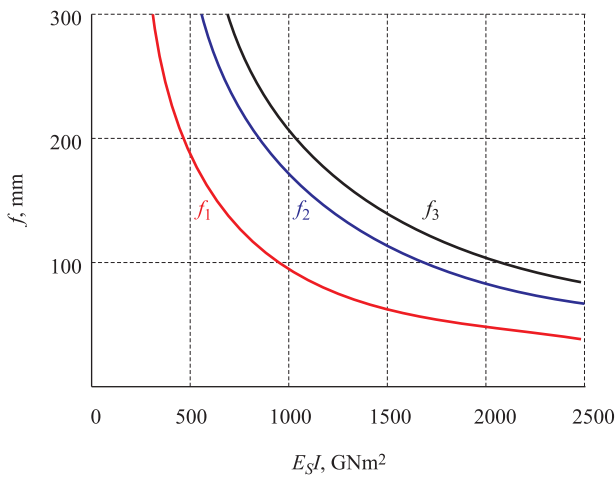

Fig. 9. Vertical displacement f (mm) of cables anchorage points depending on the stiffness $E_s I$ (GNm^2) of the stiffening girder (constant values of the stiffness of cables $E_v F_s$ are used as presented in Table 2)

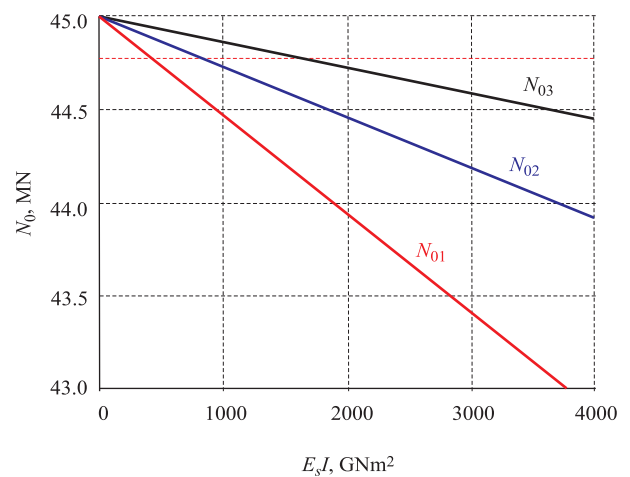

Fig. 12. Vertical component N_0 (MN) of the tensioning force of cables depending on the stiffness $E_s I$ (GNm^2) of the stiffening girders (constant values of the stiffness of cables $E_v F_s$ are used)

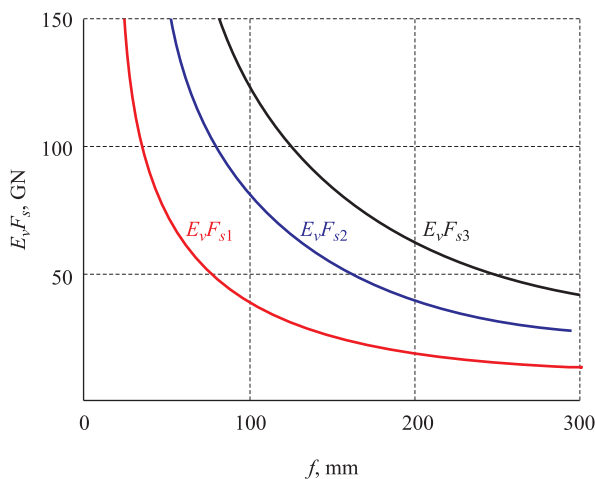

Fig. 10. Required values of stiffness of the inclined cables $E_v F_s$ (GN), depending on the displacements f (mm) of anchorage points (constant value of $E_s I$ of the stiffening girders is used)

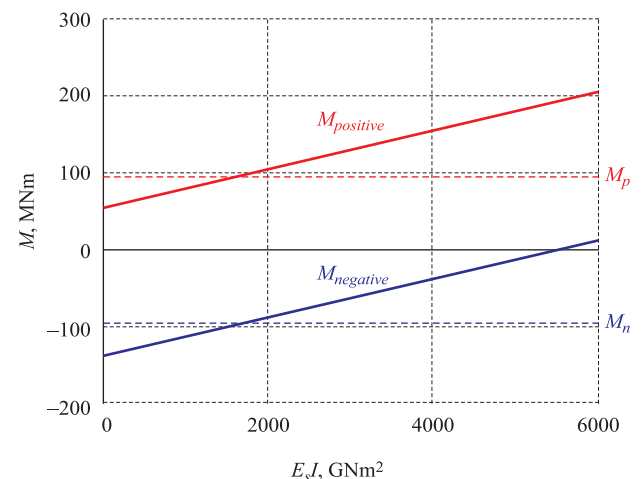

Fig. 13. Max positives and negative bending moments $M_{positive}$ (MNm) and $M_{negative}$ (MNm) depending on the stiffness $E_s I$ (GNm^2) of the stiffening girder (constant values of the stiffness of cables $E_v F_s$ are used)

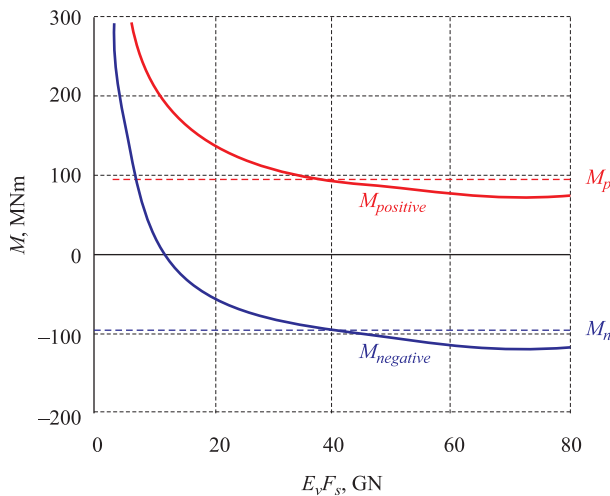

Fig. 14. Max positive and negative bending moments $M_{positive}$ (MNm) and $M_{negative}$ (MNm) depending on the stiffness $E_v F_s$ (GN) of cables (constant value $E_s I$ of the stiffening girder is used)

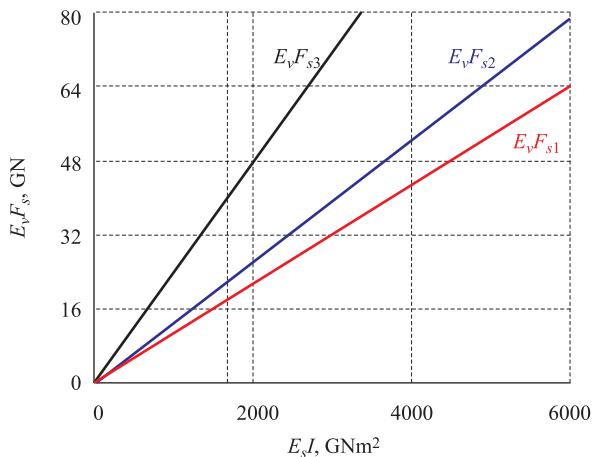

Fig. 15. The required values of stiffness of cables $E_v F_s$ (GN) depending on $E_s I$ (GNm²) of the stiffening girder

4. Perspective development of the method

This paper shows a simplified example of the cable-stayed system of bridges. The proposed approach allows analyzing also more complex systems:

- cable-stayed bridges with back spans;
- asymmetrical systems (e.g. with one pylon);
- deformations of pylons can be taken into account;
- approach can be used for analyzing the influence of variable loads (tandems defined in codes);
- structural reliability index β can be analyzed depending on the systems.

It is feasible to conduct a research of the ratio of stresses caused by variable loads. This analysis shows that by using more massive (less extensible) cables it is possible to reduce fluctuations of stresses in the stiffening girder (Di Bernardo 1998). In this way it is possible to improve the fatigue conditions.

These are few topics for further researches of the authors of this paper.

5. Conclusions

Behavior of a cable system under uniformly distributed load can be analyzed by studying deformations of their components. These correlations can be mathematically derived using the differential equations of deformed shape of girder and the tensioning forces of cables caused by their extensions.

The analysis of graphical correlations shows that by reducing the second moment of area of the stiffening girder, additionally the cross-sectional area of cables can be reduced without changing the bending moment diagram caused by uniformly distributed load. In this case the values of stiffness of components must be chosen depending on the allowable deformations of the stiffening girder (serviceability limit state).

References

- Bruer, A.; Pircher, H.; Bokan, H. 1999. Computer Based Optimizing of the Tensioning of Cable-Stayed Bridges, in *Proc. of International Association for Bridge and Structural Engineering Conference "Cable-Stayed Bridges – Past, Present and Future"*. June 2–4, 1999, Malmö, Sweden. IABSE: 65–74.
- Chen, W.-F.; Lui, E. M. 2005. *Handbook of Structural Engineering*. 2nd edition. CRC Press. 1768 p. ISBN 0849315697.
<http://dx.doi.org/10.1201/9781420039931>
- Cruz, J. S.; Almeida, J. A. 1999. A New Model for Cable-Stayed Bridges Control and Adjustment, in *Proc. of International Association for Bridge and Structural Engineering Conference "Cable-Stayed Bridges – Past, Present and Future"*. June 2–4, 1999, Malmö, Sweden. IABSE: 200–209.
- Di Bernardo, S. 1998. *Motion Based Design of Cable-Stayed Bridges*. PhD thesis. Massachusetts: Massachusetts Institute of technology. 101 p.
- Gribniak, V.; Kaklauskas, G.; Idnurm, S.; Bacinskas, D. 2010. Finite Element Mesh Size Effect on Deformation Predictions of Reinforced Concrete Bridge Girder, *The Baltic Journal of Road and Bridge Engineering* 5(1): 19–27.
<http://dx.doi.org/10.3846/bjrbe.2010.03>
- Janjic, D.; Pircher, M.; Pircher, H. 2003. Optimization of Cable Tensioning in Cable-Stayed Bridges, *Journal of Bridge Engineering* 8(3): 131–137.
[http://dx.doi.org/10.1061/\(ASCE\)1084-0702\(2003\)8:3\(131\)](http://dx.doi.org/10.1061/(ASCE)1084-0702(2003)8:3(131))
- Juozapaitis, A.; Norkus, A. 2007. Determination of Rational Parameters for the Advanced Structure of a Pedestrian Suspension Steel Bridge, *The Baltic Journal of Road and Bridge Engineering* 2(4): 173–181.
- Kachurin, V. K.; Bragin, A. V. 1971. *Designing of Suspension and Cable Stayed Bridges*. Moscow: Press Transport. 280 p.
- Kao, C.-S.; Kou, C.-H.; Xie, X. 2006. Static Instability Analysis of Long-Span Cable-Stayed Bridges with Carbon Fiber Composite Cable under Wind Load, *Tamkang Journal of Science and Engineering* 9(2): 89–95.
- Malik, J. 2004. Mathematical Modelling of Cable Stayed Bridges: Existence, Uniqueness, Continuous Dependence on Data, Homogenization of Cable Systems, *Application of Mathematics* 49(1): 1–38.
<http://dx.doi.org/10.1023/B:APOM.0000024518.38660.a3>

- Ruiz-Teran, A. M. 2010. Unconventional Cable-Stayed Bridges: Structural Behaviour and Design Criteria, *Structural Concrete* 11(1): 25–34.
<http://dx.doi.org/10.1680/stco.2010.11.1.025>
- Serdjuks, D.; Rocens, K.; Pakrastins, L. 2008. Hybride Composite Cable with an Increased Specific Strength for Tension Structures, *The Baltic Journal of Road and Bridge Engineering* 3(3): 129–136.
<http://dx.doi.org/10.3846/1822-427X.2008.3.129-136>
- Straupe, V.; Paeglitis, A. 2011. Mathematical Bases of Interaction between Elements in Cable Stayed Bridges, in *Proc. of IABSE-IASS 2011 Symposium "Taller, Longer, Lighter"*. September 20–23, 2011, London, UK. London: Hemming Group Ltd, 250. ISBN 9780707971223.
- Walther, R.; Houriet, B.; Izler, W. 1999. *Cable Stayed Bridges*. London: Thomas Telford Ltd. 227 p. <http://dx.doi.org/10.1680/csb.27732>

Received 3 October 2011; accepted 29 December 2011