



## RESEARCH ON THE OPERATION OF ROUNDABOUTS BASED ON THE SUSTAINABLE DEVELOPMENT PRINCIPLES

Henrikas Sivilevičius<sup>1</sup>✉, Gražvydas Paliulis<sup>2</sup>, Antanas Klibavičius<sup>†3</sup>, Vytautas Palevičius<sup>4</sup>

<sup>1</sup>Dept of Transport Technological Equipment, Vilnius Gediminas Technical University, Plytinės g. 27,  
10105 Vilnius, Lithuania

<sup>2, 3, 4</sup>Dept of Urban Engineering, Vilnius Gediminas Technical University, Saulėtekio al. 11, 10223 Vilnius, Lithuania  
E-mails: <sup>1</sup>henrikas.sivilevicius@vgtu.lt; <sup>2</sup>grazvydas.paliulis@vgtu.lt; <sup>4</sup>vytautas.palevicius@vgtu.lt

**Abstract.** The main elements of urban transport infrastructure include: the street network with intersections, bridges, viaducts, flyovers, vehicular traffic tunnels. Unsignalized four-leg intersections and roundabouts is the largest “saturated transport flow” of the street network. Roundabouts which were designed as far back as 1970–1980 were well-functioning when the car ownership level was 180–200 veh/1000 inhabitants. Currently, when the level of car ownership comes to 520–560 veh/1000 inhabitants, unsignalized roundabouts operate in the “oversaturated flows” regime. The research results of the Vilnius Gediminas Technical University and other universities showed that when designing new or reconstructing existing intersections the indicators of territorial planning, transport planning, environmental protection, traffic safety should be considered. As a common indicator for assessing all other indicators a monetization (estimation in monetary terms) should be used. When preparing projects for intersection reconstruction it is recommended to apply a new method of intersection analysis and evaluation based on the principles of sustainable development of urban transport infrastructure.

**Keywords:** territorial planning, roundabouts, ecological, traffic safety, recreational indicators, monetization of indicators.

### 1. Introduction

A system of road transport should operate safely, it should not contaminate environment, use small amounts of fuel and have an ability to quickly and reliably carry passengers and cargo. For this purpose adapted infrastructure of Transport System (TS) must be constantly improved by reconstructing the existing intersections. Preparation of intersection reconstruction projects involves the use of various principles, criteria and evaluation methods.

A system of road transport involves vehicles, roads, road users and freight which closely interact. The interaction between these material elements takes place in an external environment. The process of transportation is aimed at achieving some positive results which could increase the efficiency of the TS. However, negative effects such as high accident rate cannot be avoided (Podvezko, Sivilevičius 2013). The main elements of urban transport infrastructure include: street network with intersections, bridges, viaducts, flyovers, vehicular traffic tunnels. Engineering improvement of roads is in many cases inseparable from the improvement of at-grade intersections, as one of the most hazardous engineering structures.

At-grade intersections in Lithuania are currently subjected to intensive installation of different traffic engineering and safety measures (Abukauskas *et al.* 2013).

The driving speed, traffic lane width, and traffic safety (Lee, Park 2012; Mishra, Khasnabis 2012; Sarker *et al.* 2012; Zhou *et al.* 2011), fuel consumption and gas emissions (Song *et al.* 2012) as well as road user charges (Watts *et al.* 2012) depend on the geometrical parameters, amount and type of roads, city streets and intersections of the country.

Design and operation of the junction of road transport aims to provide maximum security and the lowest environmental pollution. Motor vehicle collisions with pedestrians (Kopczynski *et al.* 2011; Ptak *et al.* 2012; Sokolovskij, Prentkovskis 2013) and bicycles (Loscorn *et al.* 2013) at intersections has an impact on the increase in the number of road accidents. Pedestrians, crossing intersections in small interval, reduce their capacity (Scott *et al.* 2013).

Caliendo and Guida (2012) are modeling and assessing conflicts at deregulated intersections. Bug *et al.* (2013), Li and Elefteriadou (2013) have analyzed traffic flows at the signalized intersections. Operational performance of their right-turn-one-red have been analyzed by

Chen *et al.* (2013), and the results of capacity analysis of short left-turn lane have been delivered by Yao (2013), Yao and Zhang (2013). McGee *et al.* (2012) have proved that the red and yellow traffic light actuation time is very important.

In order to increase the urban roundabout capacity and to improve traffic safety new roundabouts are installed or four-leg intersections, the effectiveness of which is not sufficient, are reconstructed.

Today, several different types of roundabouts are well-known („mini“, „double mini“, „dumb-bell“, „with transition central island“, „with joint splitter islands“, „traffic signal controlled“, „assembled roundabouts“...) and it is possible to stipulate that they will be further developed in the future (Tollazzi, Renčelj 2014). In the literature, many analytical techniques allow the study of the performance (capacity, queues, delays, etc.) of roundabouts which are divided into two groups: analytical models and microscopic simulation models. Each method, when formulated, has to consider some aspects of roundabout circulation in comparison to others (geometric elements, vehicular flow, and user behavior) (Vaiana *et al.* 2013). Zirkel *et al.* (2013) explores the relationship between sight distance parameters, crash rates, and operating speeds at low-volume single-lane roundabouts in the United States. The understanding of the interaction of design, operations, and crash performance is a step forward in the development and application of performance-based standards for roundabouts. The specific objective of this paper (Zirkel *et al.* 2013) is to quantify the relationship between crash rates, sight distance parameters, and operating speeds to present an approach to establishing performance-based standards that highway practitioners could adopt in roundabout design.

Capacity models based on the gap acceptance theory are widely used in unsignalized intersections and roundabout capacity analysis. These models are based on the statistical distribution of major vehicle headways (Vasconcelos *et al.* 2012). Traffic flows around roundabouts have been found to be dependent on origin-destination flows, but the true nature of this relationship has not been properly understood (Dixit 2012). The present analysis is based on either gap acceptance models or empirical models. These models do not properly account for the impact of origin-destination flows on roundabout operations. Obsu *et al.* (2014) focused on instantaneous traffic flow optimization in a roundabout using a macroscopic approach. The roundabout is modelled as a concatenation of 2×2 junctions with one main lane and secondary incoming and outgoing roads.

In the study (Wong *et al.* 2012), observational and questionnaire surveys were conducted to assess how the proposed roundabout marking system affected the driver behavior, level of service, and safety performance. The vehicle travel time, number of conflicts, crash incidence, and weaving movements were assessed before and after the implementation of the observation surveys, and the perceived safety, congestion level, and lane-changing difficulties were assessed through questionnaire surveys, respectively. According to Md Diah *et al.* (2011), a weaving section flow at a conventional roundabout traffic flow situation is being

modeled using Parallel Microscopic Simulation software. The results of the simulations indicate that slight changes made to roundabout geometric design and weaving section flow parameters can affect the performance level of service (LOS) of the roundabout.

Single-lane modern roundabouts are one of the most important intersection types in the suburbs of Australia. Therefore, it is important to estimate their entry capacities (Qu *et al.* 2014). In the case study (Qu *et al.* 2014), an analytical model based on the gap acceptance theory by incorporating the effects on the existing vehicles is proposed.

Unsignalized intersections is the largest “bottleneck” of urban transport infrastructure. When designing or reconstructing roundabouts and four-leg intersections the formerly literature sources especially emphasize the roundabout safety (FGSV... 2001): small number of conflict points between flows of different directions, lower driving speed, and, thus, less severe accident consequences. However, research on roundabout functioning in Lithuanian cities showed that in roundabouts with „oversaturated” traffic flows (degree of oversaturation above 0.85) and when the crossing pedestrian flows are higher than 200 pedestrians/h in both directions, the roundabout capacity decreases by 1.4–1.6 times, time losses for the vehicles entering the intersection increase, long queues of vehicles are formed (above 20 veh) and the roundabout ensures only D and E LOS according to the HBS/HCM recommendations (FGSV... 2001; Highway... 2010; Rogers 2009). Besides, compared to typical traffic-light controlled intersections, in roundabouts the work of traffic and pedestrian flows increases, as well as the time of vehicle movement in the roundabout, large land areas are required (4000–7200 m<sup>2</sup>) for the construction of roundabouts and this under high prices of land in the central part of the city (the price of 1 are of land is ~ 60 000 EUR) increases the total cost of roundabout construction.

## 2. Problem formulation and objectives

The majority of urban roundabouts in Lithuania were designed and built in the period 1970–1984, however, there are no normative documents (STR 2.06.01. 1999 *Communication System for Cities, Towns and Villages*) or methodology recommended for designing reconstruction of this type of intersections. The paper suggests methodology for calculating capacity and efficiency of roundabouts as of important component of transport infrastructure based on modern principles of sustainable urban development and taking into consideration the impact of pedestrian flows, time spent by vehicle in the intersection, number of accidents and conflict points depending on roundabout diameter and “weaving” of flows when moving in a circle.

The subject of research – capacity of roundabouts under oversaturated traffic flows when traffic delays are additionally influenced by pedestrian flows.

The objective of research:

- to develop roundabout capacity calculation methodology when traffic flows in a circle and on entries are oversaturated;

– to develop methodology for calculating the capacity of roundabout entries and exits taking into account the priority pedestrian flows  $P_{21}$  and  $P_{22}$  which are in conflict with traffic flows;

– to assess indiscipline of the drivers entering and leaving the roundabout and to determine the impact of traffic rules violations on roundabout capacity.

#### Research methods

In the research of traffic and pedestrian flows a television camera was used where the amount of different traffic flows and their movement trajectories are filmed and later information about the flows are processed by the computer. This allows in a slow-motion regime to analyze the trajectories of different entering vehicles in a circle, also distribution in a circle between different exit directions (exit to the right, straight or to the left). The use of television camera makes it possible to make research both in small (roundabout inner diameter  $D_r < 25$  m) as well as large ( $D_r = 300$  m) roundabouts. During research and in processing the flow data an assumption was made that the arrival of different vehicles to the roundabout is close to Poisson distribution (Klibavičius, Paliulis 2012).

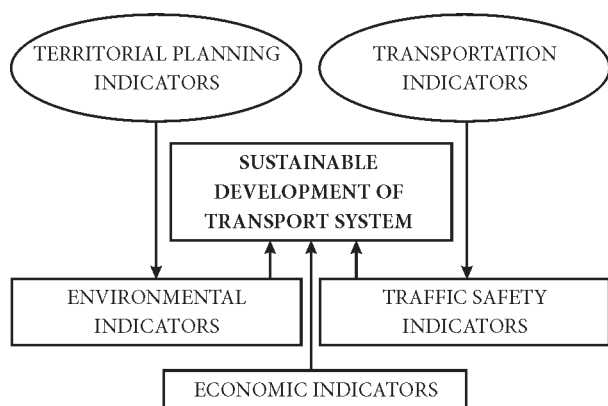

Fig. 1. Design of transport infrastructure objects using sustainable development principles

### 3. Analysis of the operation of roundabouts and four-leg intersections using sustainable development principles

Roundabouts in the cities of Lithuania were designed in the period 1970–1974 based on the standards recommending two traffic lanes for entries and three traffic lanes in a circle. Those intersections were well-functioning when the car ownership level was 180–200 veh/1000 inhabitants. Currently, when the level of car ownership comes to 520–560 veh/1000 inhabitants it is necessary to determine if the existing intersections are able to satisfy the C LOS desired by the drivers (Road... 2006) or it is necessary to move to the new traffic control methods based on the sustainable urban development principles. In order to determine operational indices of roundabouts and to compare them with the similar (according to the size of traffic flows) four-leg intersections the long-term (2006–2013) research of traffic flows were carried out in 26 roundabouts and 22 four-leg intersections of the central part of Lithuanian cities and suburban area. Analysis of roundabout capacity depending on roundabout diameter was carried out in the University of Bochum (FGSV... 2001), Urban Engineering Department of Vilnius Gediminas Technical University and Dresden Technical University (Schnabel, Lohse 2011) and the research results have been summarized in design standards and capacity calculation programs (Empfehlungen... 2011; FGSV... 2001). Diameter of the studied intersections  $D_r$  varied from 12 m to 99 m in the city centre up to 300 m in suburban area.

Design of transport infrastructure objects shall be carried out using sustainable development principles of transport systems the scheme of which is given in Fig. 1. Design of transport infrastructure objects taking into consideration the territorial planning indicators is carried out according to the total area of the territory required for the construction of intersection. Design of transport infrastructure objects taking into consideration the transportation indicators is carried out according to the work of traffic flows and intersection capacity (Table 1). When defining the work of traffic flows it is necessary to separately determine the size of traffic flows in a circle formed

Table 1. Comparison of the parameters of roundabout and four-leg intersection

Indicators of urban intersections			
Four-leg intersection		Roundabout	
1	Total area of intersection, m <sup>2</sup>	900	Total area of roundabout, m <sup>2</sup> 10568.3
2	Larger distance travelled by vehicles, veh×km/h	100	385.0
3	Larger distance travelled by pedestrians, ped×km/h	48.0	384.0
4	Number of conflict points of the intersection	28	48
5	Additional conflict points with pedestrians	8	8
	Entry – 2 traffic lanes × 3.5 m		Diameter of the inner circle, m 80.0
	Width of one traffic lane, m	3.5	Number of traffic lanes in a circle 3.0
	Distance to pedestrian crossing, m	5.00	Width of traffic lanes in a circle, m 4.0
	Width of pedestrian crossing, m	3.00	Diameter of the outer circle, m 104.0
	Width of intersection with pedestrian crossings, m	30.0	Entry –2 traffic lanes × 3.5 m
			Diameter of roundabout with sidewalks, m 116.0

between separate entries. If in four-leg intersections this is easily determined with the help of digital television cameras, in the roundabouts due to their large area and weaving of flows in a circle this stage of research requires much computer-time costs since it is not possible to use methodology for automatic vehicle image recognition, grouping and calculation. The scheme for calculating the size of traffic and pedestrian flows is given in Fig. 2.

A theoretical capacity of separate entry can be determined by the formula (1) (Astarita, Guido 2014; Wu 2006):

$$q_e = 3600 \cdot \left( 1 - \frac{t_{\min} \cdot q_c}{n_c \cdot 3600} \right)^{n_c} \cdot \frac{n_e}{t_f} \cdot \left[ \frac{1}{e^{\frac{q_c}{3600} (t_g - 0.5 t_f - t_{\min})}} \right] \quad (1)$$

$q_e$  – basic capacity of one entry (maximum entry flow), veh/h;  $q_c$  – traffic volume on the circle (flow on circulating lanes at the subject entry), veh/h;  $n_c$  – number of circulating lanes;  $n_e$  – number of entry lanes (number of lanes in the subject entry);  $t_g$  – critical gap, s;  $t_f$  – follow-up time, s; (move-up time);  $t_{\min}$  – minimum gap between succeeding vehicles on the circle (minimum headway between vehicles in the circulating lanes), s.

In order to avoid traffic jams within the roundabout in case of an accident the majority of earlier (1970–1988) designed roundabouts were designed according to the principle – the number of traffic lanes in a circle  $n_c$  is higher than the number of traffic lanes on the entries  $n_e$  and is determined by the formula (2):

$$n_c = n_e + 1. \quad (2)$$

Vehicle movement parameters depend on flow composition (Klibavičius 2007), circle diameter  $D_r$  (Rogers 2009; Schnabel, Lohse 2011), pavement condition in a circle (especially in winter). Under the urban conditions of Lithuania the following time values were determined during the research:

Minimum time between vehicles in a circle  $t_{\min} = 1.2$  s (in winter), 1.0 s (in summer).

Average time between vehicles in a circle (critical gap)  $t_g = 4.1$  s.

Average time between vehicles on the entry (move-up time)  $t_f = 2.9$  s.

Vehicle flow moving in a circle  $q_c$ , which obstructs the entering flow  $q_e$ , depends on the flow distribution of entering vehicles between different exits and flow manoeuvres when moving in a circle (Fig. 2) and is determined by the formula (3):

$$q_c = q_{12} + q_{13} + q_{14} + q_{32} + q_{42} + q_{43}. \quad (3)$$

Formula (1) was derived without taking into account pedestrian flows  $P_1$  and  $P_2$  conflicting with the entering and leaving vehicle flows. Actual flows shall be determined by the formula (4) using the flow capacity reduction

coefficient  $k_r$ , which determines the impact of pedestrian flows. Based on the long-term research of traffic flows carried out by the authors under urban conditions of Lithuania the values of reduction coefficient  $k_r$  are given in Table 2.

$$q_{pe} = q_e \cdot k_r, \quad (4)$$

$q_{pe}$  – practical capacity of entries and exits, veh/h;  $q_e$  – theoretical capacity of entries and exits, veh/h;  $k_r$  – flow capacity reduction coefficient (Table 2).

The quality of the movement of vehicles in the intersection is described by the time losses of traffic flows (in seconds per one vehicle) on the entry to the intersection –  $t_{le}$  (LOS – Level of Service) which in Lithuania is close to the values of other countries and is assumed by the Table 3.

Vehicles moving in the roundabouts when crossing the roundabout “to the right/ straight/ to the left” get an additional delay of 9/18/27 seconds. Pedestrians in the roundabouts get an additional delay (depending on roundabout diameter) of 54/96 seconds. Comparative transport indicators of intersections are given in Table 4. Table 4

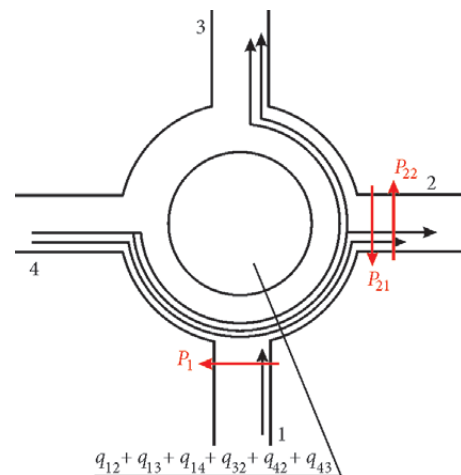

Fig. 2. The scheme for calculating the size of traffic and pedestrian flows  $P_{21}$ ,  $P_{22}$

Table 2. Reduction coefficient  $k_r$  of entering and leaving flows taking into account the pedestrian flow  $P$

The size of pedestrian flow $P$ , ped/h (in both directions)	Reduction coefficient $k_r$ when traffic flow veh/h			
	on the entry		on the exit	
	600	1000	600	1000
100	0.95	0.92	0.94	0.90
200	0.92	0.88	0.91	0.86
300	0.88	0.85	0.87	0.84
400	0.84	0.81	0.82	0.80
500	0.80	0.77	0.78	0.76
600	0.77	0.74	0.75	0.73
800	0.73	0.70	0.71	0.69
1000	0.66	0.62	0.63	0.61
1200	0.62	0.58	0.60	0.57

shows that in roundabouts additional fuel consumption amounts to 638 400 liters of fuel.

Design and assessment of transport infrastructure objects taking into consideration the *ecological indicators* is carried out based on additional fuel consumption and additional pollutant emissions into environment. Amount of pollutant emissions is given in Table 5.

Design and operation of transport infrastructure objects taking into consideration the traffic safety indicators is carried out based on the number of accidents in the intersections and the number of conflict points in the intersection of different types.

The number of conflict points in four-leg intersections, depending on the number of traffic lanes, is

**Table 3.** Time losses of traffic flows and the level of service on the entry to the intersection

Theoretical capacity of the entry $q_e$ , veh/h	Capacity reserve $R_e$ , veh/h	Time losses on the entry $t_{le}$ , s	LOS
1000	200	18	B
1000	150	21	C
1000	100	32	D
800	200	18	B
800	150	25	C
800	100	33	D
600	200	18	B
600	150	26	C
600	100	34	D
200	100	36	D
200	60	56	E*
200	40	80	E*
200	20	114	F*

\* reconstruction is necessary (Highway... 2010).

**Table 4.** The work of traffic flows in roundabouts and four-leg intersections

Indicator	Four-leg intersection	Roundabout
Work of traffic flows veh×km/h	100	385.0
Work of pedestrian flows ped.×km/h	48.0	384.0
Work of traffic flows veh×km/year	224 000	862 400
Fuel consumption l/year	22 400	86 240

**Table 5.** Amount of air pollutants in roundabouts and four-leg intersections

Pollutants	Four-leg intersection	Roundabout
1. CO, kg/year	1747	6726
2. CH, kg/year	332	1276
3. NO <sub>2</sub> , kg/year	235	905
4. SO <sub>2</sub> , kg/year	11.2	43
5. PM10, kg/year	9.0	34

given in literature sources as 28–32 points (Schnabel, Lohse 2011). The number of conflict points in roundabouts which in literature is given without taking into account the weaving of traffic flow trajectories in a circle depends on the following factors:

- traffic organization in a circle and the number of exits from the circle  $n_{out}$ ;
- inner diameter of roundabout circle  $D_r$ , m;
- the size of the whole entering flows  $\Sigma q_e$ ;
- the size of flow of a separate entry to the roundabout  $q_e$ , veh/h;
- the size of flow moving in a circle  $q_c$ , veh/h;
- part of flow distribution into separate exits of every entry to the roundabout  $q_r$  (right),  $q_d$  (directly),  $q_l$  (left);
- the number of traffic lanes in a circle  $n_c$ ;
- the number of traffic lanes on the entry to the roundabout  $n_e$ .

Based on the research of roundabout traffic flow trajectories in Lithuanian cities, carried out by the authors, a regression equation was obtained which allows calculating the number of conflict points  $n_{cs}$  in the roundabout between separate entries and exits (Fig. 3):

$$n_{cs} = \left[ (a_l \cdot q_l + a_d \cdot q_d + a_r \cdot q_r) \cdot (b_r \cdot n_c + b_l \cdot n_e) \right] \cdot 1.62 \cdot \frac{D_r}{n_{out}} \cdot \frac{q_e}{q_c}. \quad (5)$$

When the roundabout circle is provided with 3 traffic lanes and the entries – with 2 traffic lanes the values of regression coefficients are:  $a_l = 2.12$ ,  $a_d = 1.68$ ,  $a_r = 1.42$ ,  $b_r = 0.27$ ,  $b_l = 0.18$ .

The number of conflict points in this roundabout is calculation according to the regression Eq (6):

$$n_{cs} = \left[ (2.12q_l + 1.68q_d + 1.42q_r) \cdot (0.27n_c + 0.18n_e) \right] \cdot 1.62 \cdot \frac{D_r}{n_{out}} \cdot \frac{q_e}{q_c}. \quad (6)$$

The number of conflict points in the roundabouts of the central part of the city on the circle traffic lanes is located every 12–14 meters and under Lithuanian urban conditions when the circle has three traffic lanes amounts to 68–72 conflict points.

According to the statistical data, in the roundabouts of the central part of the city the number of traffic accidents is 1.47 times higher compared to four-leg intersections and traffic-light controlled intersections (Table 6). Similar indices were obtained also in the intersections of German cities (Schnabel, Lohse 2011).

For the design and evaluation of transport infrastructure objects taking into consideration the *recreational indicators* (recommended for recreational areas) the following criteria are suggested: the difference in a market price of 1 m<sup>2</sup> of immovable property objects (economic evaluation), EUR/m<sup>2</sup> for the objects situated close or further from transport infrastructure objects.

Design of transport infrastructure objects based on sustainable development principles is carried out by monetizing (estimating in monetary value) *all the indicators* (Table 7, Fig. 4), assuming the prices of various factors and applying both the Lithuanian (Road... 2006) and foreign methodologies (Empfehlungen... 2011).

#### 4. Conclusions

1. When preparing new projects of urban transport infrastructure objects – street segments, intersections, traffic control, traffic-light control and management it is necessary by applying the sustainable urban development principles to assess not only the intersection capacity but also the territorial planning, ecological and traffic safety indicators.

2. When assessing *territorial planning indicators* the following criteria are used: the total area of the territory necessary for building roundabout or four-leg intersection of appropriate capacity; economic evaluation of the total area – the price of land plot.

3. When assessing transportation indicators the following criteria are recommended: the work of traffic flows, the work of pedestrian flows, economic evaluation of the work of traffic and pedestrian flows. When calculating a capacity of the whole roundabout or separate entry to the roundabout  $q_e$  and the reserve of existing capacity  $R_e$  for urban intersections it is necessary to assess the size of pedestrian flows conflicting with traffic flows on the entries and exists  $P_1$  and  $P_2$ . When designing new or reconstructing existing roundabouts in the city it is recommended that the number of traffic lanes in a circle  $n_c$  is higher than the number of traffic lanes on the entry  $n_e$ .

4. The average vehicle waiting time losses  $t_w$  under oversaturated flows in roundabouts meet only the *E* and *F* level of service. The average length of vehicle queue  $n_{we}$  on the entry to the intersection under oversaturated flows amounts to 88–92 vehicles per peak hour blocking adjacent intersections. When calculating the capacity of separate traffic lanes on the entries and exists it is necessary to take into consideration not only the size of traffic flows, the length of vehicle queues but also pedestrian flows which reduce capacity.

5. When assessing ecological indicators the following criteria are used: traffic-generated noise level and amount of exhaust gases in the intersection by different pollutant components taking into account the work of traffic flows; economic evaluation of ecological indicators – losses for the national economy due to environmental pollution.

6. When assessing traffic safety indicators the following criteria are used: the number of fatal and injury accidents per year and the number of damage-only accidents per year; economic evaluation of traffic safety indicators – losses for the national economy due to traffic accidents, Euro/year. The number of conflict spots in roundabouts, influencing traffic safety of the roundabout, depends on the size of flow, flow distribution between separate exits, roundabout diameter and in 99.0 m diameter roundabout the number of conflict points is 72. Analysis of 2004–2013 statistical data of roundabout accidents in Vilnius and

Klaipėda cities showed that when the capacity of roundabout entries has been already used (oversaturation degree of the flows  $g_{sat} > 0.85$ ) the number of fatal, injury and damage-only accidents is ~ 1.47 times higher compared to

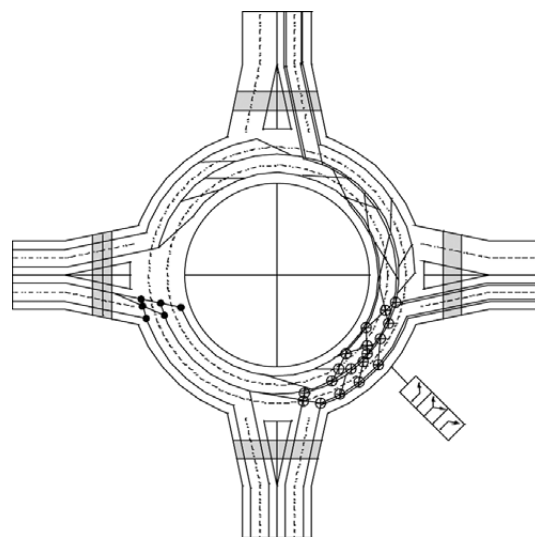

**Fig. 3.** The scheme of conflict points in roundabouts: ◊ – when manoeuvring in a circle; ● – on the entries in a circle

**Table 6.** Accidents in four-leg intersections and roundabouts in Vilnius, 2006–2010 (Klibavičius, Paliulis 2012)

	Traffic accidents	Four-leg intersection	Roundabout
1. Fatal accidents		1	1
2. Injury accidents		11	14
3. Damage-only accidents		38	53

**Table 7.** Economic indicators for the operation of roundabouts and four-leg intersections

	Indicator	Objective
1.	The price of land plot, EUR/year	min
2.	Fuel price, EUR/year	min
3.	Vehicle operating costs, EUR/year	min
4.	Environmental losses caused by pollution with exhaust gases, EUR/year	min
5.	Accident losses, EUR/year	min

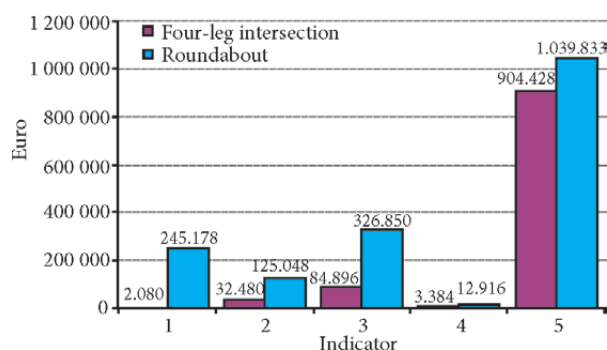

**Fig. 4.** Economic comparison of intersection and roundabout in the city

that in the intersections similar by their flow size (2+2 traffic lanes) where traffic flows are controlled by traffic-lights.

7. When assessing *recreation indicators* (recommended for recreational areas) the following criteria are suggested: the difference in a market price of 1 m<sup>2</sup> of immovable property objects (economic evaluation), EUR /m<sup>2</sup> for the objects situated close or further from transport infrastructure objects.

8. When assessing a payback of the *whole project* the methods of monetization (estimation in monetary value) should be used giving a possibility to make an accurate evaluation of not only the existing situation but also of the long-term effects of project impact.

## References

- Abukauskas, N.; Sivilevičius, H.; Puodžiukas, V.; Lingytė, I. 2013. Road Safety Improvement on at-Grade Intersections, *The Baltic Journal of Road and Bridge Engineering* 8(3): 212–219. <http://dx.doi.org/10.3846/bjrbe.2013.27>
- Astarita, V.; Guido, G. 2014. Analysis of Non-Conventional Roundabouts Performances through Microscopic Traffic Simulation, *Applied Mechanics and Materials* 505–506: 481–488. <http://dx.doi.org/10.4028/www.scientific.net/AMM.505-506.481>
- Bugg, Z.; Roupail, N. M.; Schroeder, B. 2013. Lane Choice Model for Signalized Intersections with an Auxiliary through Lane, *Journal of Transportation Engineering* 139(4): 371–378. [http://dx.doi.org/10.1061/\(ASCE\)TE.1943-5436.0000513](http://dx.doi.org/10.1061/(ASCE)TE.1943-5436.0000513)
- Caliendo, C.; Guida, M. 2012. Microsimulation Approach for Predicting Crashes at Unsignalized Using Traffic Conflicts, *Journal of Transportation Engineering* 138(12): 1453–1467. [http://dx.doi.org/10.1061/\(ASCE\)TE.1943-5436.0000473](http://dx.doi.org/10.1061/(ASCE)TE.1943-5436.0000473)
- Chen, X.; Qi, Y.; Liu, G. 2013. Empirical Study of Gap-Acceptance Behavior of Right-Turn-on-Red Drivers on Dual Right-Turn Lanes, *Journal of Transportation Engineering* 139(2): 173–180. [http://dx.doi.org/10.1061/\(ASCE\)TE.1943-5436.0000489](http://dx.doi.org/10.1061/(ASCE)TE.1943-5436.0000489)
- Dixit, V. V. 2012. Modeling Origin-Destination Effects on Roundabout Operations and Inflow Control, *Journal of Transportation Engineering* 138(8): 1016–1022. [http://dx.doi.org/10.1061/\(ASCE\)TE.1943-5436.0000394](http://dx.doi.org/10.1061/(ASCE)TE.1943-5436.0000394)
- Empfehlungen für Wirtschaftlichkeitsuntersuchungen an Straßen. (Aktuelle Redaktion). 2011, 55S.
- FGSV. 2001. Handbuch für die Bemessung von Straßenverkehrsanlagen (HBS, 2001 Germany Highway Capacity Manual). Forschungsgesellschaft für Straßen- und Verkehrswesen (Hrsg.), No 299, FGSV Verlag GmbH, Köln.
- Highway Capacity Manual (HCM) 2010. Transportation Research Board. Washington DC. 2010. 1024 p.
- Kopczyński, A.; Ptak, M.; Harnatkiewicz, P. 2012. The Influence of Frontal Protection System Design on Pedestrian Passive Safety, *Archives of Civil and Mechanical Engineering* 11(2): 345–364.
- Klibavičius, A.; Paliulis, G. M. 2012. Increasing the Capacity of Intersections by Short Traffic Lanes, *Transport* 27(1): 67–72. <http://dx.doi.org/10.3846/16484142.2012.666764>
- Klibavičius, A. 2007. Issledovanie propusknoy sposobnosti kol'tsevykh perekrestkov. Social and Economic Problems of Town Transport Systems and Areas of Their Influence Development. *Proceeding Materials*. Ekaterinburg, p. 130–136.
- Lee, J.; Park, B. B. 2012. Determining Lane Use Distribution Using Basic Freeway Segment Density Measures, *Journal of Transportation Engineering* 138(2): 210–217. [http://dx.doi.org/10.1061/\(ASCE\)TE.1943-5436.0000313](http://dx.doi.org/10.1061/(ASCE)TE.1943-5436.0000313)
- Li, Z.; Elefteriadou, L. 2013. Minimizing the Traffic Throughput of Turn Bays at a Signalized Intersection Approach, *Journal of Transportation Engineering* 139(5): 425–432. [http://dx.doi.org/10.1061/\(ASCE\)TE.1943-5436.0000514](http://dx.doi.org/10.1061/(ASCE)TE.1943-5436.0000514)
- Loscorn, J.; Mills, A. F.; Brady, J. F.; Duthic, J. C.; Machemehl, R. B. 2013. Effects of Bicycle Boxes on Bicyclist and Motorist Behavior at Intersections in Austin, Texas, *Journal of Transportation Engineering* 139(10): 1039–1046. [http://dx.doi.org/10.1061/\(ASCE\)TE.1943-5436.0000584](http://dx.doi.org/10.1061/(ASCE)TE.1943-5436.0000584)
- McGee, H.; Mariarty, K.; Gates, T. J. 2012. Guidelines for Timing Yellow and Red Intervals at Signalized Intersections, *Transportation Research Record* 2298: 1–8. <http://dx.doi.org/10.3141/2298-01>
- Md Diah, J.; Abdul Rahman, M. Y.; Adnan, M. A.; Hooi Ling, K. 2011. Modelling the Relationship Between Geometric Design and Weaving Section Flow Process of Conventional Roundabouts, *Journal of Transportation Engineering* 137(12): 980–986. [http://dx.doi.org/10.1061/\(ASCE\)TE.1943-5436.0000290](http://dx.doi.org/10.1061/(ASCE)TE.1943-5436.0000290)
- Mishra, S.; Khasnabis, S. 2012. Optimization Model for Allocating Resources for Highway Safety Improvement at Urban Intersections, *Journal of Transportation Engineering* 138(5): 535–547. [http://dx.doi.org/10.1061/\(ASCE\)TE.1943-5436.0000364](http://dx.doi.org/10.1061/(ASCE)TE.1943-5436.0000364)
- Obsu, L. L.; Goatín, P.; Kassa, S. M. 2014. Gradient-Base Instantaneous Traffic Flow Optimization on a Roundabout, *HAL Archives-Outverters*: 1–12. Available from Internet: <https://hal.inria.fr/hal-00935351>
- Podvezko, V.; Sivilevičius, H. 2013. The Use of AHP and Rank Correlation Methods for Determining the Significance of the Interaction between the Elements of a Transport System Having a Strong Influence on Traffic Safety, *Transport* 28(4): 389–403. <http://dx.doi.org/10.3846/16484142.2013.866980>
- Ptak, M.; Rusinski, E.; Kazlinski, J.; Dragan, S. 2012. Evaluation of Kinematics of SUV to Pedestrian Impact-Lower Leg Impactor and Dummy Approach, *Archives of Civil and Mechanical Engineering* 12(1): 68–73. <http://dx.doi.org/10.1016/j.acme.2012.03.016>
- Qu, X.; Ren, L.; Wang, S.; Oh, E. 2014. Estimation of Entry Capacity for Single-Lane Modern Roundabouts: Case Study in Queensland, Australia, *Journal of Transportation Engineering* 140(7): CID: 05014002. [http://dx.doi.org/10.1061/\(ASCE\)TE.1943-5436.0000675](http://dx.doi.org/10.1061/(ASCE)TE.1943-5436.0000675)
- Road Investment Manual. 2006. Road and Transport Research Institute, Kaunas, 2006, 88 p.
- Rogers, M. 2009. *Highway Engineering*. 2<sup>nd</sup> edition. Dublin: Blackwell Publishing. 336 p.
- Sarker, B. R.; Baylot, E. A.; Green, J. G.; Biswas, P. 2012. Convoy Movement: Consideration of Burning Geometrics for Selected Vehicle Shapes, *Journal of Transportation Engineering* 138(5): 502–511. [http://dx.doi.org/10.1061/\(ASCE\)TE.1943-5436.0000359](http://dx.doi.org/10.1061/(ASCE)TE.1943-5436.0000359)
- Schnabel, W.; Lohse, D. 2011. Grundlagen der Straßenverkehrstechnik und der Verkehrsplanung. Band 1. Verlag fuer Bauwesen. Berlin. 624 p.

- Scott, A. C.; Swenson, L. J.; Bentzen, B. L.; Barlow, J. M. 2013. Countdown-only Pedestrian Change Interval Displays. Effect on Signal Recognition by Pedestrians with Reduced Visual Acuity, *Transportation Research Record* 2384: 10–17. <http://dx.doi.org/10.3141/2384-02>
- Sokolovskij, E.; Prentkovskis, O. 2013. Investigating Traffic Accidents: the Interaction Between a Motor Vehicle and Pedestrian, *Transport* 28(3): 302–312. <http://dx.doi.org/10.3846/16484142.2013.831771>
- Song, G.; Yu, L.; Tu, Z. 2012. Distribution Characteristics of Vehicle-Specific Power on Urban Restricted-Access Roadways, *Journal of Transportation Engineering* 138(2): 202–209. [http://dx.doi.org/10.1061/\(ASCE\)TE.1943-5436.0000318](http://dx.doi.org/10.1061/(ASCE)TE.1943-5436.0000318)
- STR 2.06.01:1999. *Miestų, miestelių ir kaimų susisiekimo sistemos* [Communication System for Cities, Towns and Villages]. Vilnius, 2012. 48 p.
- Tollazzi, T.; Renčelj, M. 2014. Comparative Analyse of the Two New Alternative Types of Roundabouts-Turbo and Flower Roundabout, *The Baltic Journal of Road and Bridge Engineering* 9(3): 164–170. <http://dx.doi.org/10.3846/bjrbe.2014.21>
- Vaiana, R.; Galleli, V.; Iuele, T. 2013. Sensitivity Analysis Traffic Microscopic Simulation Model for Roundabouts, *The Baltic Journal of Road and Bridge Engineering* 8(3): 174–183. <http://dx.doi.org/10.3846/bjrbe.2013.22>
- Vasconcelos, L.; Silva, A. B.; Seco, A.; Silva, J. 2012. Estimating the Parameters of Cowan' M3 Headway Distribution for Roundabout Capacity Analyses, *The Baltic Journal of Road and Bridge Engineering* 7(4): 261–268. <http://dx.doi.org/10.3846/bjrbe.2012.35>
- Watts, M. V.; Zech, W. C.; Turochy, R. E.; Holman, D. B.; LaMonia, J. J. 2012. Effects of Vehicle Volume and Lane Closure Length on Construction Road User Costs in Rural Areas, *Transportation Research Record* 2268: 3–11. <http://dx.doi.org/10.3141/2268-01>
- Wong, S. C.; Sze, N. N.; Loo, B. P. Y.; Chow, A. S. Y.; Lo, H. K.; Hung, W. T. 2012. Performance Evaluations of the Spiral-Marking Roundabouts in Hong Kong, *Journal of Transportation Engineering* 138(11): 1377–1387. [http://dx.doi.org/10.1061/\(ASCE\)TE.1943-5436.0000433](http://dx.doi.org/10.1061/(ASCE)TE.1943-5436.0000433)
- Wu, N. 2006. Capacity Enhancement and Limitation at Roundabouts with Double-Lane or Flared Entries, in *Proc. of the 5<sup>th</sup> International Symposium on Highway Capacity and Quality of Service*: vol 2. 25–29 July, 2006, Yokohama, Japan: 459–468.
- Yao, R. 2013. Sensitivity Analysis of Optimization Models for Two Adjacent Intersections with Correlated Short Left-Turn Lanes, *Transport* 28(3): 256–269. <http://dx.doi.org/10.3846/16484142.2013.829781>
- Yao, R.; Zhang, M. 2013. Optimal Allocation of Lane Space and Green Splits of Isolated Signalized Intersections with Short Left-Turn Lanes, *Journal of Transportation Engineering* 139(7): 667–677. [http://dx.doi.org/10.1061/\(ASCE\)TE.1943-5436.0000551](http://dx.doi.org/10.1061/(ASCE)TE.1943-5436.0000551)
- Zhou, S.; Sun, J.; An, X.; Li, K. 2011. The Development of a Conflict Hazardous Assessment Model for Evaluating Urban Intersection Safety, *Transport* 26(2): 216–223. <http://dx.doi.org/10.3846/16484142.589494>
- Zirkel, B.; Park, S.; McFadden, J.; Angelastro, M.; McCarthy, L. 2013. Analysis of Sight Distance, Crash Rate, and Operating Speed Relationships for Low-Volume Single-Lane Roundabouts in the United States, *Journal of Transportation Engineering* 139(6): 565–573. [http://dx.doi.org/10.1061/\(ASCE\)TE.1943-5436.0000532](http://dx.doi.org/10.1061/(ASCE)TE.1943-5436.0000532)

Received 21 October 2014; accepted 20 December 2014