

ESTIMATING THE EFFECTS OF PUBLIC TRANSPORT PRIORITY MEASURES  
AT SIGNAL CONTROLLED INTERSECTIONSVytautas Dumbliauskas<sup>1</sup>, Vytautas Grigonis<sup>2</sup>✉, Jūratė Vitkienė<sup>3</sup>

Dept of Roads, Vilnius Gediminas Technical University, Saulėtekio al. 11, LT–10223 Vilnius, Lithuania  
E-mails: <sup>1</sup>vytautas.dumbliauskas@vgtu.lt; <sup>2</sup>vytautas.grigonis@vgtu.lt; <sup>3</sup>jurate.vitkiene@vgtu.lt

**Abstract.** Most of the Lithuanian cities try to achieve public transport priority by the provision of special dedicated public transport lanes. However, the possible priority measures at signalised intersections receive less attention. This paper explains common signal control strategies applied at isolated intersections in the cities around the world and estimated their effects on the travel times of both, public transport and general traffic. The analysis employs well recognised PTV VISSIM simulation environment and VisVAP graphical programming interface to implement and test priority measures under question. The results indicate that priority actions significantly reduce public transport delays up to 60%, without high adverse impact on general traffic delays.

**Keywords:** public transport priority, PTV VISSIM, VisVAP, signal control strategies.

## 1. Introduction

In practice, traffic signal control of isolated intersections mainly has two alternatives: fixed time control and actuated (semi-actuated or fully actuated) control.

In fixed time control, stage sequence, cycle length, and splits are constant and independent of traffic demand, which has to be served at the intersection. Isolated intersection featuring fixed time control usually has several predefined signal programs, switched during different periods of the day. Predominantly, intersections have signal programs that are tailored to morning peak, off-peak and evening peak periods (Hamilton *et al.* 2013).

In actuated control, for road safety reasons, the sequence of stages is usually pre-determined. However, the cycle length and the time devoted to each stage varies on a cycle-by-cycle basis and strictly depends on demand (Pascale *et al.* 2012).

Figure 1 illustrates the operation of an actuated stage, based on the three critical settings: minimum green, maximum green, and unit extension. When the green is initiated for a stage, it is at least as long as the minimum green period. The controller divides the minimum green into an initial portion and a portion equal to one unit extension. If a call is received during the last  $U$  seconds (Unit Extension) of the minimum green,  $U$  seconds of green is added to the stage. After that, every time an additional call is received during a unit extension of  $U$  seconds, an extra period of  $U$  seconds is added to the green. Because the unit extension is the amount of time added to the green

stage when an additional actuation is received, it must be of sufficient length to allow a vehicle to travel from the detector to the stop line.

The main advantage of actuated control over fixed time control is natural recovery from oversaturation and priority interruptions. When leading to and recovering from temporal oversaturation, actuated control makes full use of capacity, ending the green on stages whose queues has dissipated and switching to stages, which still have a queue (Cesme, Furth 2014). Actuated control has compensation mechanisms making it amenable to aggressive public transport priority. If a priority interruption cuts a

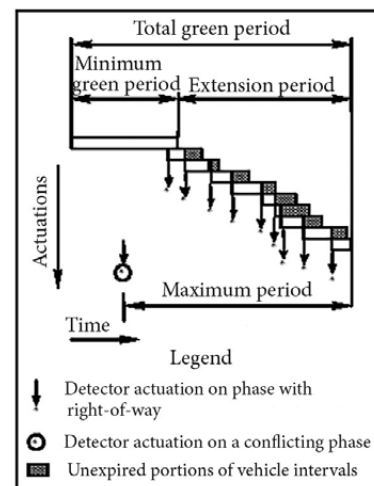

Fig. 1. Operation of an actuated stage

stage short and creates a longer-than-usual queue, the green of a stage automatically adjusts its length in the next cycle to dissipate its queue (subject to maximum green). A compensation mechanism like this is a critical aspect of making traffic signal control well suited to transit priority (Furth et al. 2010).

In general, bus priority measures are classified into two different groups: passive and active priority actions. In passive priority signal timings are re-optimised, to take into account streams of traffic containing significant bus flows. Passive priority is a straightforward form of precedence at traffic signals that give more green time to the approach. It is having a higher flow of public transport vehicles. Active priority to public transport vehicles is provided by making the traffic signal responsive to the arrival of each vehicle detected on the approach. Most commonly used active bus priority measures are: green time extension, recall, and stage skipping (Ahmed 2014; Gardner et al. 2009; Guler, Menendez 2014).

These forms of public transport priority have been implemented in many cities in the USA, the United Kingdom, Japan, France, Denmark, Sweden, Switzerland, Finland, Germany, Australia, Austria, Italy and New Zealand and others. For example, London (the United Kingdom) started bus priority trials more than twenty years ago in 1988, and at the moment, bus priority is installed at 509 pedestrian signals and 1389 signalised intersections (844 SCOOT junctions and 545 VA junctions) (Ahmed et al. 2016).

Figure 2 outlines the idea of the green time extension.

Green time extension involves the extension of the green for a stage with the public transport route upon

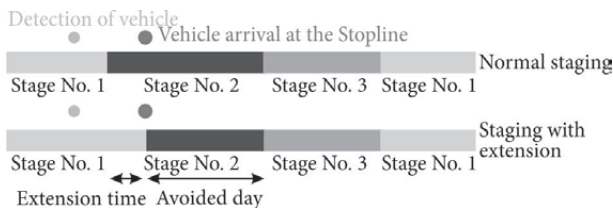

Fig. 2. Green time extension

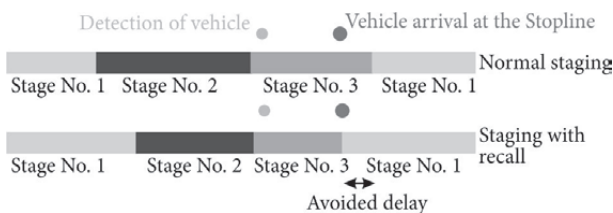

Fig. 3. Recall of the competing stage

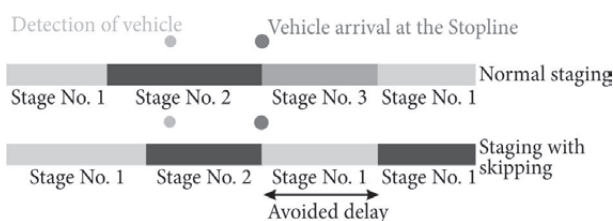

Fig. 4. Skipping of the competing stage

detection of a public transport vehicle until it clears the intersection or when the pre-specified maximum green extension (or max-timer) is reached. A max-timer is usually used to set the maximum extension limit of the priority stage, needed to control the disruption of other general traffic and to terminate the excessively long bus priority calls.

Figure 3 outlines the idea of the recall of the competing stage.

Recall measure involves the shortening of either all or some selected non-bus stages. However, when designing the maximum length of an early green, particular attention is paid to the minimum green restriction, the clearance safety of the other stages (including vehicle and pedestrian stages), and the excessive delay of the truncated approaches. A recall would cause more disruption to other traffic than a green extension would because it incurs more interference to the traffic signal settings (Ahmed 2014; McLeod 1998).

Figure 4 outlines the idea of the skipping of the competing stage.

In many countries, stage skipping is an uncommon practice, and its implications for safety need to be carefully considered. Of particular interest is the potential effect on regular users of an intersection who become familiar with the normal operation, particularly when they receive a green at the next stage change. When a stage is skipped, this normal order is interrupted. Users, anticipating their green, are caught out when the bus stage, rather than their expected stage, is given green. However, no adverse effects were observed in the trials conducted in London (United Kingdom) where great care was taken with the implementation (Gardner et al. 2009; Nordfjærn et al. 2014).

The main goal of this work is to estimate the impact of public transport priority measures on the travel times of both, public transport and general traffic.

The organisation of the article is as follows. Initially, the article describes tools employed for the analysis, then thoroughly discusses the methodology and, finally, two last sections are dedicated to the presentation of the results and discussion of their implication.

## 2. Tools

The analysis carried out in this study is essentially based on three interrelated tools, the simulation environment PTV VISSIM, and its add-on module Vissig and VisVAP graphical programming environment.

PTV VISSIM is a little time step, and behaviour-based simulation model developed to model urban traffic, public transport operations and flows of pedestrians (Koukol, Pribyl 2013). The psycho-physical car-following model created by Prof Rainer Wiedemann and implemented in PTV VISSIM was developed at the Karlsruhe Institute of Technology in 1974 and 1999. It describes the movement of traffic on a single lane. The user easily adjusts the model via parameters in line with local conditions. Additionally,

there also are behaviour models for lane changing and lateral behaviour within a lane.

Vissig is an additional PTV VISSIM module, used for the development of fixed time control strategies. It allows convenient and fast development of stage-based signal programs that is more systematic approach than its signal group based rival.

Finally, VisVAP enhances the use of freely-definable signal control logics using the VAP (Vehicle Actuated Programming) language in offering a comfortable tool for creating and editing program logics as flow charts.

Figure 5 briefly describes the architecture of working files used to model signal control with Vissig and VisVAP in PTV VISSIM environment.

For the use of VisVAP control, the definition of signal groups, stages, and interstages are done using Vissig and exported to a text file (\*.pua). Then, program logic is defined in VisVAP also checks for structural correctness and if successful exports it to a VAP file. This way the creation of VAP files for the use within PTV VISSIM is much easier than writing VAP code directly.

### 3. Methodology

The analysis in this study is based on the simulation of hypothetical signalised intersection, whose characteristics are typical to many remote urban nodes. This section describes initial assumptions and the framework of model development, in particular: demand and network structure, signal control logic scenarios and simulation periods.

#### 3.1. Demand

For the sake of simplicity, it is assumed that general traffic consist only of light vehicles and there is no heavy goods traffic on the network. General traffic demand rate is assumed to vary according to stair step function as shown in Fig. 6 to realistically imitate traffic dynamics during peak hour.

As it is seen from the diagram, traffic demand is changed every ten minutes. At the beginning and end of the simulation, the demand is 55% of the peak rate that is modelled during middle twenty minutes. The following Fig. 7 reveal the distribution of peak rate among the intersection turns.

Every intersection approach features turning distribution of 1:3:1 means that 60% of the flow goes ahead and the remaining traffic is equally distributed between left and right turns. This relative distribution is kept constant during all simulation periods.

The demand for public transport is assumed to be constant through all simulation period. Two public transport routes are modelled on the main road, one for eastbound direction and one for westbound direction. Each has a departing rate of one vehicle every three minutes.

#### 3.2. Network structure

Fig. 8 reveals the structure of the network modelled. Each main road approach has two through lanes and 50 m length left turn flare. Meanwhile, each side road approach has only one through the lane and a 40 m length left turn flare.

Detectors placed on the approaches identify the headways among two successive vehicles (1), report when the left turn flares are filled (2) and inform signal control logic about arriving and leaving public transport vehicles (3). In practise, the physical detectors sensing arriving and departing buses are replaced by virtual detectors, employing the Global Positioning System (Ahmed *et al.* 2016).

#### 3.3. Method of control

In traffic control logic, which follows three stages (Fig. 9), is implemented, which run in the depicted order. First pictured stage serves through and right turn movements on the main road, while the second stage is responsible for the main road left turn protected movements. Finally, the third pictured stage in charge of traffic running on the side road.

The interstages among stages were designed according to road safety requirements with a goal to reduce the

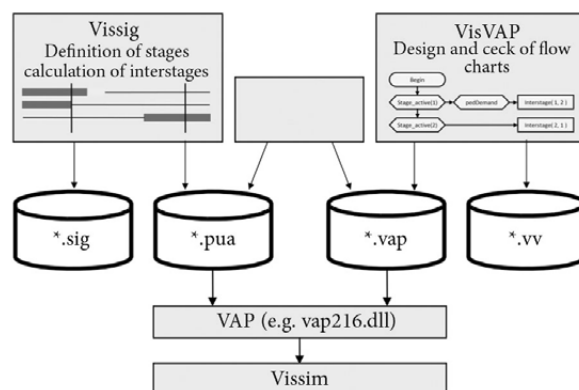

Fig. 5. Architecture of working files

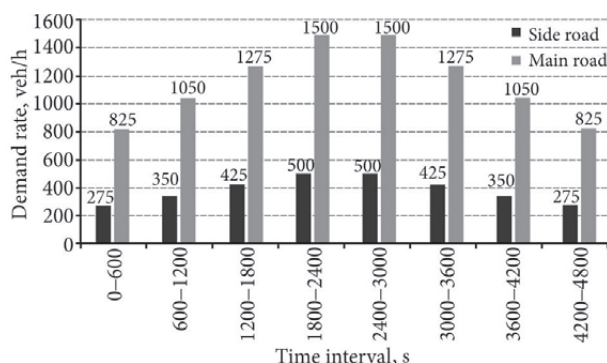

Fig. 6. Dynamics of general traffic demand rate

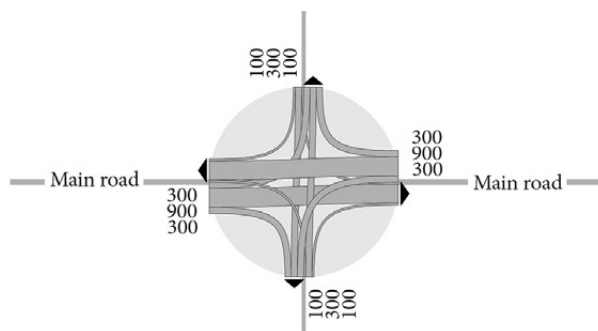

Fig. 7. Directional distribution of demand rate

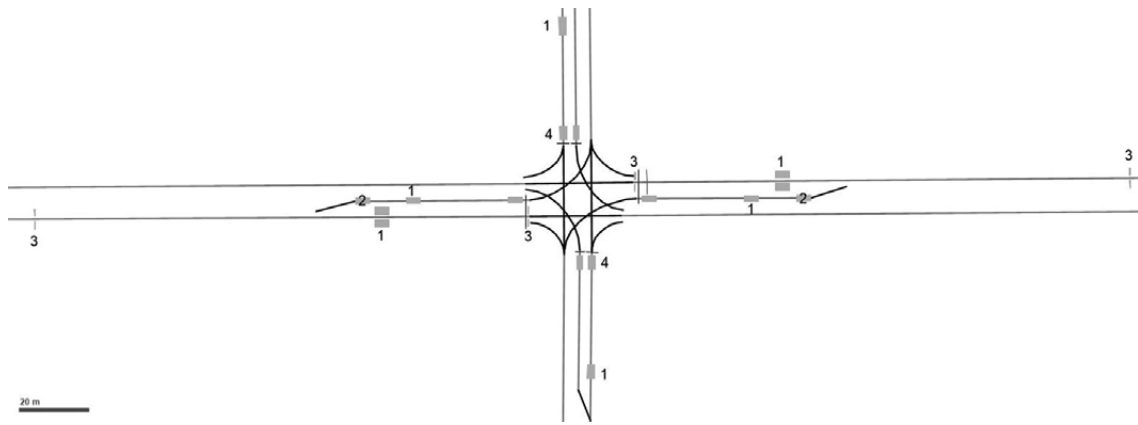

Fig. 8. PTV VISSIM network structure and allocation of detectors

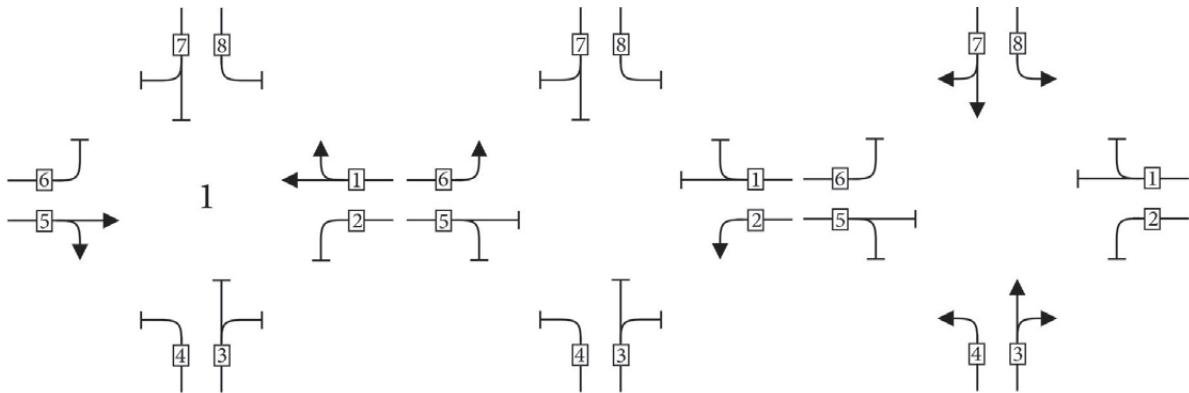

Fig. 9. Signal control stages

probability of collision. Three different control algorithms were tested under the same network structure and demand characteristics, specifically, optimized fixed time control, actuated monitor and actuated control with public transport priority measures. Simulation results of each signal control are then compared to in the section that follows.

### 3.4. Fixed time control

Optimised fixed time control features constant cycle time and stage split times. Cycle time and stage split times have been optimised with PTV VISUM software according to Highway Capacity Manual procedure for the peak demand rate to deliver minimum delays. This scenario is particularly characteristic to many real on-street situations as a peak time signal program, usually optimised for only short 15–20 minutes peak demand rate, and is run for a wider period, for example, 1 to 2 hours or even longer.

### 3.5. Actuated control

Actuated traffic signal control logic features variable cycle time caused by variable green times. This control logic has the extension rule for each stage and blocking back prevention rule from protected left turn stage. Blocking back prevention rule, generally ensures that after the main road left turn flares to become filled up, the green immediately goes to the Stage No. 2.

### 3.6. Actuated control logic with partial public transport priority

To augment simple actuated control logic with public transport priority measures, such as green time extension (of Stage No. 1), recall (from Stage No. 2 or Stage No. 3) and stage skipping (of Stage No. 3), an additional set of detectors is necessary. They sense arriving and leaving public transport vehicles. Public transport vehicles approaching the intersection has to be detected in advance, to ensure appropriate switching of green signal. The time reserve depends on the length of interstages, minimum green times and the anticipated speed of public transport vehicles.

For a full public transport priority, worst case scenario is when a public transport vehicle is detected at the onset of interstage to the competing stage, so the time reserve needed consists of two interstages and one period of minimum green time. However, in this work, a partial priority is given to public transport vehicles with the time reserve consisting of one interstage and one minimum green period.

The control logic works as follows:

- if arriving a public transport vehicle is detected, and Stage No. 1 has a green, this green is extended for a period necessary for a public transport vehicle to leave the intersection;
- if arriving bus is detected and Stage No. 1 has red, then the competing stage is terminated, and green is given back to Stage No. 1.

The proposed control strategy ensures so-called partial public transport priority, as there are the cases when public transport vehicle do not receive a green light at the arrival at a traffic light:

- if public transport vehicle arrives at the traffic light when the maximum green time of Stage No. 1 is reached. In this case, public transport vehicle is delayed for the period consisting of two interstages and one minimum green time;
- if arriving public transport vehicle is detected immediately after onset of interstage to the competing stage. In this case, public transport vehicle is delayed for the period consisting of one interstage.

More aggressive public transport priority is also be implemented. However, this would result in higher overall traffic delays.

### 3.7. Simulation periods

The whole simulation period is divided into subperiods according to the best practice (Ghods, Fu 2014). The entire simulation interval consists of one hour and twenty minutes and is divided into following periods: warm up period, study period, cool down period.

The purpose of the warm up period is to pre-load the network with traffic and generate queues during the analysis period. This period covers first 10 min of the simulation, during which demand rate is 55% of the peak demand rate.

The purpose of the study period is to collect necessary data for comparison of different signal control scenarios. This period covers 60 min, during which the demand rate varies between 70% and 100% of peak demand rate.

The cool-down period that follows the study period allows vehicles trapped in the network at the end of the survey period to reach their destination, and therefore be reflected in the simulation evaluation data. Without a cool-down period, performance results are biased.

## 4. Results and discussion

Simulation results are gathered by averaging measures of performance over twenty simulation runs with starting random seed of one and increment of one to get statistically reliable estimates.

Average delay per vehicle, a measure of return considered as the most suitable for this study, collected from general traffic and public transport vehicles separately. The diagram in Fig. 10 reveals the dynamics of each average general traffic delay, estimated for ten-minute intervals of the study period.

As it is seen from the actuated control logic outperforms fixed time controller at the intervals of low traffic demand, specifically first and last ten minutes. This result indicates that actuated control adapts to low traffic flows, thus reducing overall traffic delay. However, as demand rate gets closer to the peak demand rate, the performance of fixed time and actuated control is almost identical.

It is worth to notice that actuated traffic control with public transport priority does have an only negligible

adverse effect on the delays of general traffic. For example, during first and last ten minutes of the study period, this control logic gives even lower general traffic delays compared to fixed time control (by 17% and 8% accordingly). However, with higher demand rates, the general traffic delays increase by up to 14%.

The following diagram (Fig. 11) provides data about each average public transport delays of each scenario, estimated for ten-minute intervals of the study period.

Regarding public transport delays, actuated control algorithm outperforms fixed time control by 10% to 39%. Only the third interval is exceptional and features an increase of 10%. Finally, after implementation of public transport priority measures, public transport delays are reduced by 37% to 60% compared to fixed time control. Also, the variability of the delay among the separate intervals is reduced significantly. So, under this control logic, fluctuation of general traffic demand rate has only negligible effect on public transport travel times.

The negative impact on general traffic travel times is reduced if the priority is to be given only to late public transport vehicles. The so called conditional priority helps limit crowding and improve service reliability while at the same time creating less disruption for other traffic (Furth, Muller 2000).

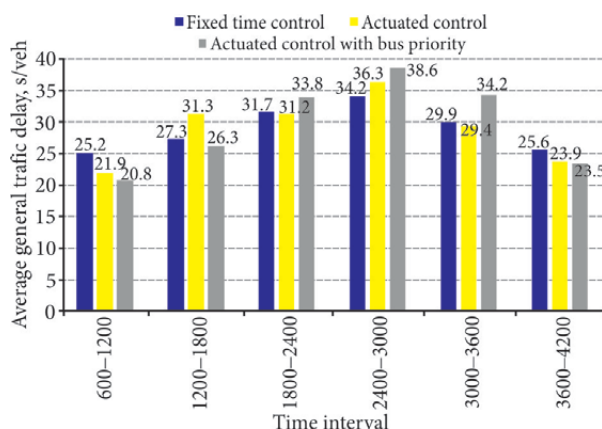

Fig. 10. Dynamics of average general traffic delay

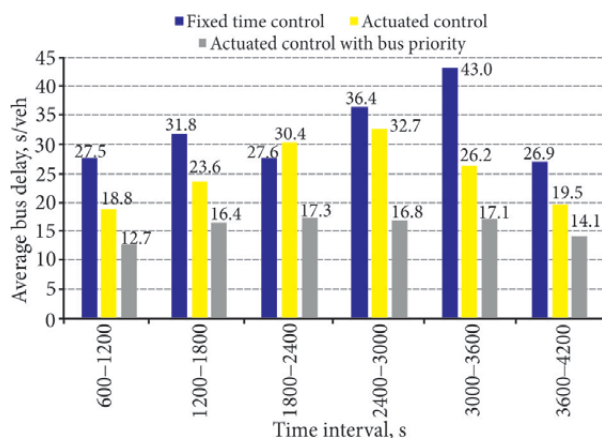

Fig. 11. Dynamics of average public transport delay

## 5. Conclusions

1. Public transport priority measures are classified into two different groups: passive and active priority actions, most commonly used active bus priority measures include: green extension, recall, and stage skipping.

2. VisVAP graphical programming environment provides the necessary flexibility to simulate various signal control algorithms, including public transport priority measures, in PTV VISSIM simulation environment.

3. The case study research has shown that implementation of public transport priority measures such as green extension, recall, and stage skipping reduce public transport delays by 37% to 60% compared to fixed time control without high adverse impact on general traffic delays. General traffic delays increase only by up to 14%.

4. Public transport priority measures also reduce the variability of the public transport delays, which in turn would make transport timetables more reliable.

## References

- Ahmed, B.; Hounsell, N.; Shrestha, B. 2016. Investigating Bus Priority Parameters for Isolated Vehicle Actuated Junctions, *Transportation Planning and Technology* 39(1): 45–58. <https://doi.org/10.1080/03081060.2015.1108082>
- Ahmed, B. 2014. Exploring New Bus Priority Methods at Isolated Vehicle Actuated Junctions, *Transportation Research Procedia* 4: 391–406. <https://doi.org/10.1016/j.trpro.2014.11.030>
- Cesme, B.; Furth, P. G. 2014. Self-Organizing Traffic Signals Using Secondary Extension and Dynamic Coordination, *Transportation Research Part C: Emerging Technologies* 48: 1–15. <https://doi.org/10.1016/j.trc.2014.08.006>
- Furth, P.; Muller, T. H. 2000. Conditional Bus Priority at Signalized Intersections: Better Service with Less Traffic Disruption, *Transportation Research Record* 173: 23–30. <https://doi.org/10.3141/1731-04>
- Furth, P. G.; Cesme, B.; Rima, T. 2010. Signal Priority Near Major Bus Terminal: Case Study of Ruggles Station, Boston, Massachusetts, *Transportation Research Record* 2192: 89–96. <https://doi.org/10.3141/2192-08>
- Gardner, K.; D'Souza, C.; Hounsell, N.; Shrestha, B.; Bretherton, D. 2009. *Review of Bus Priority at Traffic Signals Around the World*, UITP Working Group Technical Report.
- Ghods, A. H.; Fu, L. 2014. Real-Time Estimation of Turning Movement Counts at Signalized Intersections Using Signal Phase Information, *Transportation Research Part C: Emerging Technologies* 47: 128–138. <https://doi.org/10.1016/j.trc.2014.06.010>
- Guler, S. I.; Menendez M. 2014. Analytical Formulation and Empirical Evaluation of pre-Signals for Bus Priority, *Transportation Research Part B: Methodological* 64: 41–53. <https://doi.org/10.1016/j.trb.2014.03.004>
- Hamilton, A.; Waterson, B.; Cherrett, T.; Robinson, A.; Snell, I. 2013. The Evolution of Urban Traffic Control: Changing Policy and Technology, *Transportation Planning and Technology* 36(1): 24–43. <https://doi.org/10.1080/03081060.2012.745318>
- Koukol, M.; Pribyl, O. 2013. Design Methodology of a Fuzzy Control System in PTV VISSIM, *Transactions on Transport Sciences Warsaw* 6(4): 177–184. <https://doi.org/10.2478/v10158-012-0045-9>
- McLeod, F. 1998. Headway-Based Selective Priority to Buses, in *Proc. of the 3<sup>rd</sup> IMA Conference on Mathematics in Transport Planning and Control*, 1–3 April 1988, Cardiff, Wales, the United Kingdom. 69–78. Emerald Group Publishing Limited. <https://doi.org/10.1108/9780585474182-007>
- Nordfjærn, T.; Şimşekoğlu, Ö.; Lind, H. B.; Jørgensen, S. H.; Rundmo, T. 2014. Transport Priorities, Risk Perception and Worry Associated with Mode Use and Preferences among Norwegian Commuters, *Accident Analysis and Prevention* 72: 391–400. <https://doi.org/10.1016/j.aap.2014.07.028>
- Pascale, A.; Nicoli, M.; Deflorio, F.; Dalla Chiara, B.; Spagnolini, U. 2012. Wireless Sensor Networks for Traffic Management and Road Safety, *IET Intelligent Transport Systems* 6(1): 67–77. <https://doi.org/10.1049/iet-its.2010.0129>

Received 15 February 2017; accepted 9 June 2017